

# **'Draft Report of the Expert Committee on Odour Pollution & its Control'**

**--- Invitation of Comments**

**Draft**

**REPORT OF THE EXPERT COMMITTEE  
ON ODOUR POLLUTION & ITS  
CONTROL**

**JULY 2007**

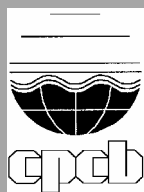

**CENTRAL POLLUTION CONTROL BOARD  
Ministry of Environment & Forests,  
Govt. of India  
Parivesh Bhawan, East Arjun Nagar, Delhi – 1100 32**

## **FOREWORD**

Odour is a sensory response to the chemicals in the inhaled air. Air quality is affected not only due to conventional air pollutants but also due to unpleasant odour. The main effect of odour is nuisance, but in more serious cases it may lead to feelings of nausea and headache, and other symptoms that appear to be related to stress. Odour has distinctly different characteristics and is undoubtedly the most complex of all the air pollution problems. Till date, not much attention has been paid towards odour problems in the country.

Considering the likely increase in odour problem in the country, the Central Pollution Control Board (CPCB) constituted an 'Expert Committee on Odour Pollution & its Control' to look into the extent of problem, its measurement, control and regulation aspects.

The Committee included experts from National Environmental Engineering Research Institute (NEERI), Nagpur; National Chemical Laboratory (NCL), Pune; Central Pulp & Paper Research Institute (CPPRI), Saharanpur; Central Leather Research Institute (CLRI), Chennai; Central Labour Institute, Mumbai; Municipal Corporation of Delhi, New Delhi and experts from the industries.

The Committee was constituted in October, 2002. This report is the outcome of six meetings and detailed discussions with experts from various fields / industries. The report of the Committee is submitted herewith to the Central Pollution Control Board. The Report deals with the basics of odour pollution, its sources, measurement, control technologies, case studies in India, International regulations / legislations etc. This report may serve as a guideline for odour pollution and its control.

I express my thanks to all the Committee members for giving their valuable time and suggestion in preparation & finalization of this report. Technical input and secretarial support provided by CPCB is acknowledged.

I hope this document will be useful to Pollution Control Boards and other concerned agencies.

**(Paritosh C. Tyagi)**

Chairman of the Expert Committee  
on Odour Pollution & its Control

## **Expert Committee on Odour Pollution & its Control**

- Shri Paritosh Tyagi, Ex-Chairman, CPCB, Delhi  
**(Chairman of the Committee)**
- Dr. R. A. Pandey, Assistant Director, National Environmental Engineering Research Institute (NEERI), Nagpur
- Dr. H. G. Joglekar, Sr. Scientist, National Chemical Laboratory (NCL), Pune
- Shri Suresh Panwar, Scientist E-I, Central Pulp & Paper Research Institute (CPPRI), Saharanpur
- Dr. M. C. Bardiya, Senior General Manager, Daurala Sugar Works, Daurala,
- Dr. S. Rajamani, Director Grade Scientist, Central Leather Research Institute (CLRI), Chennai
- The Commissioner, Municipal Corporation of Delhi, New Delhi
- Shri V. S. Bhatanagar, Ex. Director, CSIO, Chandigarh
- Shri S. S. Gautam, Deputy Director, Regional Labour Institute (RLI), Kanpur
- Dr. G. N. Qazi, Deputy Director, Regional Research Laboratory (RRL), Jammu
- Shri Kamlesh Udani, Gujarat Industrial Development Corporation, Ankelshwar
- Dr. V. Krishna, Chief Research Manager, Indian Oil Corporation, Faridabad
- Dr. Sanchita Jindal, Ministry of Environment & Forests, New Delhi

### **Invitees**

- Dr. Rakesh Agrawal, Director, Envirotech Instruments (Private) Ltd.
- Dr. H. M. Behl, Deputy Director, National Botanical Research Institute, Lucknow
- Dr D. D. Basu, Senior Scientist, Central Pollution Control Board, Delhi

### **CPCB Participation**

Dr. B. Sengupta, Member Secretary, Central Pollution Control Board, Delhi

Shri J. S. Kamyotra, Additional Director, Central Pollution Control Board, Delhi

Shri A. P. Srivastava, Senior Engineer, CPCB, Delhi

Shri G. K. Mendiratta, Environmental Engineer, CPCB, Delhi

Mrs Anjna Singh, Assistant Environmental Engineer, CPCB, Delhi



# Contents

<b>S. No.</b>	<b>Contents</b>	<b>Page No.</b>
1.0	Introduction	6
2.0	Effects of Odour	7
3.0	Odorous Compounds	7
4.0	Sources of Odour	9
5.0	Odour Index	11
6.0	Measurement of Odour	13
	6.1 Terms Associated with Odour Measurement	13
	6.2 Odour Measurement	14
7.0	Odour Control Technologies	
	7.1 Odour Control from Area Sources	16
	7.2 Odour Control from Point Sources	19
8.0	Case Studies carried out in India	
	8.1 Study carried out in Andhra Pradesh Paper Mills Limited	28
	8.2 Study carried out by Central Pulp & Paper Research Institute, Saharanpur	30
	8.3 Study carried out in Daurala Sugar Factory & Distillery	31
	8.4 Case Study – Odour Control in Municipal Solid Waste Treatment Plant, Chennai	33
9.0	Legislations, Standards and Regulations for Measurement of Odour	33
10.0	Recommendations	39
	References	41
	Annexure – I	43
	Annexure – II	49
	Annexure – III	52

## **List of Tables**

	<b>Title</b>	<b>Page No.</b>
1.	Details of Offensive Odorous Compounds Emitted from Industries	8
2.	Important Sources of Odour Pollution & Odorous Compounds emitted	11
3.	Odour Indices of the Common Odorous Compounds	12
4.	Comparison of different Methods of Measurement	55
5.	Comparison of different Control Methods of Measurement	57

## **List of Figures**

	<b>Title</b>	<b>Page No.</b>
1.	Conditions for Potential Foul Odour	9
2.	Working of a Rotary Atomizer	18
3.	A Typical Atomizer Installation for Odour Control	19
4.	A Catalytic Oxidizer System	21
5.	Bio-filters for Odour Control	22
6.	Dynamic Olfactometry – Test Apparatus	45
7.	Dynamic Olfactometry – Test Apparatus	47

# Report on Odour Pollution & its Control

## 1.0 INTRODUCTION

Odour can be defined as the “perception of smell” or in scientific terms as “a sensation resulting from the reception of stimulus by the olfactory sensory system”. Whether pleasant or unpleasant, odour is induced by inhaling air-borne volatile organics or inorganics.

With growing population, industrialization and urbanization, the odour problem has been assuming objectionable proportion. Urbanization without proper sanitation facilities is a major cause of odour problem. Rapidly growing industrialization has aggravated the problem through odorous industrial operations. Undesirable odour contributes to air quality concerns and affect human lifestyles. Odour is undoubtedly the most complex of all the air pollution problems.

Unlike conventional air pollutants, odour has distinctly different characteristics, which, to an extent, can be comparable with noise pollution. Similar to noise, nuisance is the primary effect of odour on people. Some such characteristics are:

- Substances of similar or dissimilar chemical constitution may have similar odour. Nature and strength of odour may change on dilution.
- Weak odour is not perceived in presence of strong odour.
- Odour of same strength blends to produce a combination in which one or both may be unrecognizable.
- Constant intensity of odour causes an individual to quickly lose awareness of the sensation and only noticed when it varies in intensity.
- Fatigue for one odour may not affect the perception of dissimilar odour but will interfere with the perception of similar odour.
- An unfamiliar odour is more likely to cause complaint than a familiar one.
- Two or more odorous substances may cancel the smell of each other.
- Odour travels downwind.
- Person can smell at a distance.
- Many animals have keener sense of olfaction than man.
- Likes and dislikes often depend on association of the scent with pleasant or unpleasant experiences.

## **2.0 EFFECTS OF ODOUR**

Odour affects human beings in a number of ways. Strong, unpleasant or offensive smells can interfere with a person's enjoyment of life especially if they are frequent and / or persistent. Major factors relevant to perceived odour nuisance are:

- Offensiveness
- Duration of exposure to odour
- Frequency of odour occurrence
- Tolerance and expectation of the receptor

Though foul odour may not cause direct damage to health, toxic stimulants of odour may cause ill health or respiratory symptoms. Secondary effects, in some, may be nausea, insomnia and discomfort. Very strong odour can result in nasal irritation, trigger symptoms in individuals with breathing problems or asthma. On the economic front, loss of property value near odour causing operations/ industries and odorous environment is partly a consequence of offensive odour.

## **3.0 ODOROUS COMPOUNDS**

Odorous substances that are emitted from industrial sources include both inorganic and organic gases and particulate. Many odorous compounds result from biological activity or are present in emissions from chemical processes. Most of the odorous substances derived from anaerobic decomposition of organic matter contain sulfur and nitrogen. Some of the odorous compounds emitted from industrial sources and their volatility & detection thresholds are given in Table-1. Most of the odorous substances are gaseous under normal atmospheric conditions or at least have a significant volatility. Usually, lower the molecular weight of a compound, the higher is its vapor pressure & potential for emission to the atmosphere. Substances of high molecular weight are normally less volatile and thus normally have less odour. The reduced sulfur compounds, such as the mercaptans and organic sulfides, tend to be the most odorous, based on their relatively low odour threshold concentrations.

**Table -1**  
**Details of Offensive Odorous Compounds Emitted from Industries**

Sl. No.	Compound/ Odorant	Formula	Molecular Weight	Volatility at 25°C in ppm	Odour Detection Threshold in ppm (v/v)	Offensive Odour Description
1.	<b>Inorganic Compounds</b>					
	▪ Ammonia	NH <sub>3</sub>	17	Gas	17	Pungent, Irritating
	▪ Chlorine	Cl <sub>2</sub>	71	Gas	0.080	Pungent, Suffocation
	▪ Hydrogen Sulphide	H <sub>2</sub> S	34	Gas	0.00047	Rotten eggs
	▪ Ozone	O <sub>3</sub>	48	Gas	0.5	Pungent, irritating
	▪ Sulphur dioxide	SO <sub>2</sub>	64	Gas	2.7	Pungent, irritating
2.	<b>Acids</b>					
	▪ Acetic Acid	CH <sub>3</sub> COOH	60	Gas	1.0	Vinegar
	▪ Butyric Acid	CH <sub>3</sub> CH <sub>2</sub> CH <sub>2</sub> COOH	88	Gas	0.12	Rancid butter
	▪ Propionic Acid	CH <sub>3</sub> CH <sub>2</sub> COOH	74	Gas	0.028	
3.	<b>Alcohols</b>					
	▪ Amyl alcohol	C <sub>5</sub> H <sub>11</sub> OH	88	Gas	---	---
	▪ Butyl alcohol	CH <sub>3</sub> (CH <sub>2</sub> ) <sub>3</sub> OH	74	Gas	0.10	--
4.	<b>Aldehydes &amp; Ketones</b>					
	▪ Formaldehyde	HCHO	30			Acrid
	▪ Acetaldehyde	CH <sub>3</sub> CHO	44	Gas	0.067	Fruit
	▪ Butylaldehyde	C <sub>3</sub> H <sub>7</sub> CHO	72			Rancid
	▪ Acetone	CH <sub>3</sub> COCH <sub>3</sub>	58			Fruit
5.	<b>Amines</b>					
	▪ Methyl amine	CH <sub>3</sub> NH <sub>2</sub>	31	Gas	4.7	Putrid, Fishy
	▪ Dimethyl amine	(CH <sub>3</sub> ) <sub>2</sub> NH	45	Gas	0.34	Putrid, Fishy
	▪ Trimethyl amine	(CH <sub>3</sub> ) <sub>3</sub> N	59	Gas	0.0004	Putrid, Fishy
	▪ Ethyl amine	C <sub>2</sub> H <sub>5</sub> NH <sub>2</sub>	45		0.27	Ammoniacal
	▪ Diethyl amine	(C <sub>2</sub> H <sub>5</sub> ) <sub>2</sub> NH	129		0.020	
	▪ Di-isopropyl amine	(C <sub>3</sub> H <sub>7</sub> ) <sub>2</sub> NH <sub>2</sub>	101		0.13	Fishy
	▪ Dibutyl amine	(C <sub>4</sub> H <sub>9</sub> ) <sub>2</sub> NH	129	8,000	0.016	Fishy
	▪ n butyl amine	CH <sub>3</sub> (CH <sub>2</sub> ) <sub>3</sub> NH <sub>2</sub>	73	93,000	0.080	Sour, ammonia
6.	<b>Mercaptans</b>					
	▪ Allyl mercaptan	CH <sub>2</sub> CHCH <sub>2</sub> SH	74	---	0.0015	Disagreeable, garlic
	▪ Amyl mercaptan	CH <sub>3</sub> (CH <sub>2</sub> ) <sub>4</sub> SH	104	---	0.0003	Unpleasant, Putrid
	▪ Benzyl mercaptan	C <sub>6</sub> H <sub>5</sub> CH <sub>2</sub> SH	124	---	0.0002	Unpleasant, strong
	▪ Ethyl mercaptan	C <sub>2</sub> H <sub>5</sub> SH	62	710,000	0.0003	Decayed Cabbage
	▪ Methyl mercaptan	CH <sub>3</sub> SH	48	Gas	0.0005	Rotten Cabbage
	▪ Phenyl mercaptan	C <sub>6</sub> H <sub>5</sub> SH	110	2,000	0.0003	Putrid, garlic
	▪ Propyl mercaptan	C <sub>3</sub> H <sub>7</sub> SH	76	2,20,000	0.0005	Unpleasant
7.	<b>Sulphides</b>					
	▪ Diethyl sulphide	(C <sub>2</sub> H <sub>5</sub> ) <sub>2</sub> S	106		0.02	Ether
	▪ Dimethyl sulphide	(CH <sub>3</sub> ) <sub>2</sub> S	62	830,000	0.001	Decayed Cabbage
	▪ Dimethyl disulphide	(CH <sub>3</sub> ) <sub>2</sub> S <sub>2</sub>	94		0.0076	Putrid
	▪ Diphenyl sulphide	(C <sub>6</sub> H <sub>5</sub> ) <sub>2</sub> S	186	100	0.0001	Unpleasant
8.	<b>Organic Heterocycles</b>					
	▪ Indole	C <sub>8</sub> H <sub>7</sub> (CH) <sub>2</sub> NH	117	360	0.0001	Faecal, nauseating
	▪ Pyridine	C <sub>5</sub> H <sub>5</sub> N	79	27,000	0.0001	Pungent, irritating
	▪ Skatole	C <sub>9</sub> H <sub>9</sub> N	131	200	0.001	Faecal, nauseating
	▪ Thiocresol	CH <sub>3</sub> C <sub>6</sub> H <sub>4</sub> SH	124	---	0.0001	Rancid

Source: Journal of Indian Association for Environmental Management, Vol. 29, Feb, 2002

#### 4.0 SOURCES OF ODOUR

Most commonly reported odour-producing compounds are hydrogen sulfide (rotten egg odour) and ammonia (sharp pungent odour). Carbon disulfide, mercaptans, product of decomposition of proteins (especially of animal origin) phenols and some petroleum hydrocarbons are other common odorants. Most offensive odour is created by the anaerobic decay of wet organic matter such as flesh, manure etc. For example, odour originating from livestock manure is a result of a broad range of over 168 odour-producing compounds. Warm temperature enhances anaerobic decay and foul odour production, as represented in Figure 1.

Odour sources can be classified as:

- **Point Sources:** Point sources are confined emissions from vents, stacks and exhausts.
- **Area Sources:** Area sources may be unconfined like sewage treatment plant, waste water treatment plant, solid waste landfill, composting, household manure spreading, settling lagoons etc.
- **Building Sources:** Building sources of odour like pig sheds and hog confinement chicken.
- **Fugitive Sources:** In this source of odour, emissions are of fugitive nature like odour emissions from soil bed or bio-filter surface.

Odour can arise from many sources. Most of the sources are man-made. Garbage/improper dumping on vacant land is a common phenomenon. It leads to foul smell due to putrefaction of dumped garbage, which lies uncollected for days together. Unscientific design of landfill & improper sewage treatment practices produce unpleasant odour.

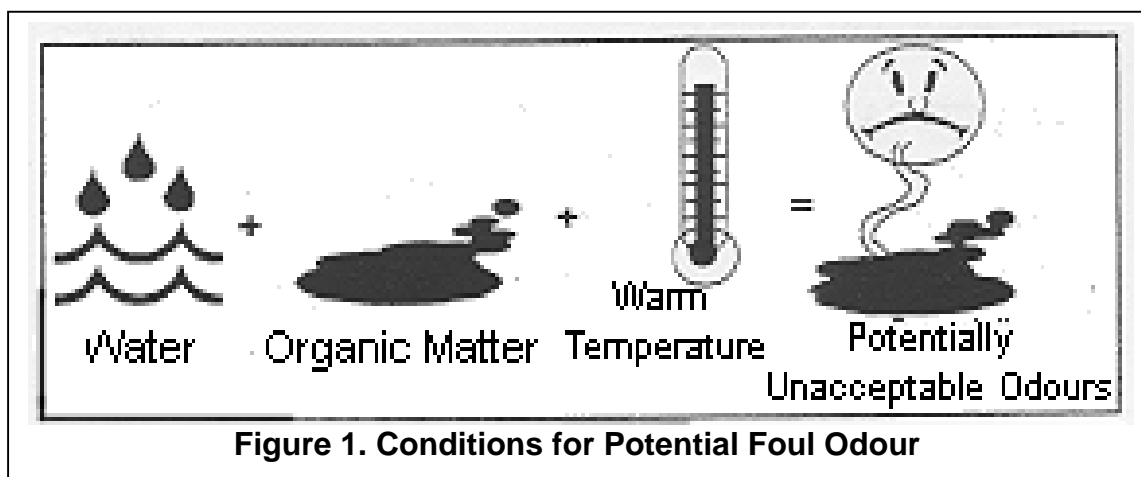

Industries such as Pulp & Paper, Fertilizer, Pesticides, Tanneries, Sugar & Distillery, Chemical, Dye & Dye Intermediates, Bulk Drugs & Pharmaceuticals etc, Large Livestock operations, Poultry Farms, Slaughter Houses, Food and Meat processing industries and Bone Mills are among major contributors to odour pollution. Agricultural activities like decaying of vegetation, production and application of compost etc. also contribute to odour pollution.

In urban areas, improper handling of public amenities like toilets of cinema hall, bus / railway stations, hospitals, shopping complex etc. generate pungent odour, which affects the users as well as neighbourhood residents. Congested markets do not allow the escape of odour from markets, thus causing problems to shop-owners as well as to customers.

Vehicular sector also has its share in odour pollution. Rapidly growing vehicular population as well as pollutants emitted by them generate harmful and pungent odour that have marked effects on pedestrians as well as near-by residents.

Some of the important sources of odour pollution, the specific section / sources in the process and odorous compounds emitted are listed in Table - 2.

**Table – 2**  
**Important Sources of Odour Pollution and Odorous Compounds Emitted**

Sources	Sections	Odorous Compounds
<b>Pulp &amp; Paper</b>	Digester	CH <sub>3</sub> SH
	Black Liquor Storage Tank	CH <sub>3</sub> SH, CH <sub>3</sub> · <sub>2</sub> S
	Evaporator	H <sub>2</sub> S, CH <sub>3</sub> · <sub>2</sub> S <sub>2</sub> , CH <sub>3</sub> · <sub>2</sub> S
	Recovery Boiler	CH <sub>3</sub> SH, CH <sub>3</sub> · <sub>2</sub> S
	Smelt Dissolving Tank	H <sub>2</sub> S, CH <sub>3</sub> SH
	Lime kiln	CH <sub>3</sub> SH, SO <sub>2</sub>
<b>Fertilizers</b>	Nitrogenous Phosphatic	NH <sub>3</sub> , SO <sub>2</sub> , F <sub>2</sub>
<b>Pesticides</b>		CH <sub>3</sub> CHO, NH <sub>3</sub> , H <sub>2</sub> S
<b>Tanneries</b>	Raw hides and skins storage / waste fleshing	Putrifaction of Hides & Skins
	Beam house operation	NH <sub>3</sub> , H <sub>2</sub> S
	Finishing operation	Volatile organic compounds
	ETP: Collection Tanks	H <sub>2</sub> S
	ETP: Primary Treatment Units	H <sub>2</sub> S
	ETP: Sludge Dewatering System	H <sub>2</sub> S
	ETP: Anaerobic Lagoons	H <sub>2</sub> S, CH <sub>4</sub>
<b>Sugar &amp; Distillery</b>	Bio-methanation	H <sub>2</sub> S
	Aeration Tank	NH <sub>3</sub>
<b>Chemical</b>	-	NH <sub>3</sub> H <sub>2</sub> S, Cl <sub>2</sub> , Mercaptans & Phenols
<b>Dye &amp; Dye Intermediates</b>	-	NH <sub>3</sub> , H <sub>2</sub> S, SO <sub>2</sub> , Mercaptans,
<b>Bulk Drugs &amp; Pharmaceuticals</b>	Biological extracts and wastes spent termination liquors	H <sub>2</sub> S, SO <sub>2</sub> , Mercaptans,
<b>Waste Water Treatment Plant</b>	Anaerobic decomposition	H <sub>2</sub> S & Mercaptans
<b>Municipal Solid Waste</b>	Anaerobic decomposition	H <sub>2</sub> S, Mercaptans
<b>Slaughter Houses</b>	By-product / Waste Storage Effluent Treatment Plant	CH <sub>4</sub> , H <sub>2</sub> S, Mercaptans
<b>Hazardous Wastes Dumpsites</b>		
<b>Hospital Waste &amp; Incinerators</b>		
<b>Food Processing</b>		
<b>Petrochemical</b>		

## 5.0 ODOUR INDEX

The odour index is defined as the dimensionless ratio of the vapour pressure and the 100% odour recognition threshold (the concentration at which 100 % of the odour panel detect /recognised the odour as being representative of the odorant being studied). The odour index provides information on the potential of a particular compound to cause odour problems under evaporative conditions. The odour indices of the common odorous compounds are given in Table -3.

**Table - 3**  
**Odour Indices of the Common Odorous Compounds**

<b>Compound</b>	<b>Odour Index</b>
Acetaldehyde	4,300,000
Acetic acid	15,000
Acetic anhydride	12,800
Acetone	720
Acrylic acid	4,210
Allyl alcohol	13,800
Allyl chloride	17,900
Ammonia	167,300
Benzaldehyde	22,000
Benzene	300
Benzyl chloride	28,000
1,3 butadiene	2,530
n-butane	480
n-butanol	120
Sec. butanol	400
Tert. Butanol	55,900
n-butylacetate	1,200
n-butylamine	395,000
n-butylchloride	6,300
n-butylether	13,400
n-butylmercaptan	49,340,000
n-butylsulfide	658,000
n-butyric acid	50,000
Carbon disulfide	44,430
Carbon tetrachloride	540
Chlorobenzene	52,600
Chlorobromomethane	350
Chloroform	70
Diethylamine	880,000
Diethylsulfide	14,400,000
Diethylketone	1,900
Dimethylamine	280,000
Dimethylsulfide	2,760,000
Ethane	25,300
Ethanol	11
Ethylacetate	1,900
Ethylene	57,100
Ethylether	1,939,000
Formaldehyde	5,000,000
Hydrogen sulfide	17,000,000
Isobutane	3,000,000
Isobutanol	320
Isobutene	4,640,000
Isobutylacetate	3,300
Methanol	22
Methylacetate	1,100
Methylamine	940,000
Methylamylalcohol	12,650
Methylchloride	200,000
phenol	16
Propane	425
Propionic acid	112,300
Skatole	30,000
Toluene	720
Valeric acid	256,300

*Source: NEERI, Nagpur*

## 6.0 MEASUREMENT OF ODOUR POLLUTION

Of the five senses, the sense of smell is the most complex and unique in structure and organization. Sense of smell is accomplished with two main nerves. The olfactometry nerve (first cranial nerve) processes the perception of chemicals. The trigeminal nerve (fifth cranial nerve) processes the irritation or pungency (sensation) of chemicals. All olfactory signals meet in the olfactory bulb where the information is distributed to two different parts of the brain. One major pathway of information is to the limbic system which processes emotion and memory response of the body. The second major information pathway is to the frontal cortex. This is where conscious sensations take place, as the information is processed with other sensations and is compared with accumulated life experiences for the individual to possibly recognize the odour and make some decisions about the experiences. The entire trip, from nostril to signal in the brain, takes as little as 500 milliseconds.

### 6.1 Terms associated with Odour Measurement

For better understanding of the methods of measurement of odour, definition of following few terms is required:

- **Odour Detectability or Threshold or Concentration:** Odour detectability or threshold or concentration is a sensory property referring to the minimum concentration that produces an olfactory response or sensation. With odour intensity at or just above “threshold” odour become difficult to perceive.

An **odour detection threshold** relates to the minimum odorant concentration required to perceive the existence of the stimulus, whereas an **odour recognition threshold** relates to the minimum odorant concentration required to identify the stimulus. The detection threshold occurs at a lower concentration than the recognition threshold.

Odour concentration is measured as dilution ratios and reported as Dilution Threshold and Recognition Threshold or Dilution to Threshold (D/T) and sometimes assign the pseudo-dimension of odour units per cubic meter.

Dilution to Threshold (D/T) ratio is a measure of the number of dilutions needed to make the odorous air non-detectable.

Odour unit is the concentration divided by the threshold.

- **Odour Intensity:** Odour intensity is the strength of the perceived odour sensation. Perceived odour intensity is the relative strength of the odour above the recognition threshold. It is related to the odorant concentration. Generally odour intensity increases with the odorant concentration. The relationship between intensity and concentration, can be expressed as:

$$I = k (C)^n$$

or  $\text{Log } I = \text{Log } K + n \text{ Log } (C)$

where,

I - Intensity;  
C - concentration;  
k - constant and  
n - exponent,

This is known as Stevens' law or the power law. For odours, n ranges from about 0.2 to 0.8, depending on the odourant. For an odorant n equal to 0.2, a tenfold reduction in concentration decreases the perceived intensity by a factor of only 1.6, whereas for an odorant with n equal to 0.8, a tenfold reduction in concentration lowers the perceived intensity by a factor of 6.3. This is an important concept that is related to the basic problem of reducing the odour intensity of a substance by air dilution or other means.

Odour Intensity is expressed in parts per million of butanol.

The odour intensity is usually stated according to a predetermined rating system. Widely used scale for odour intensity is the following:

1	-	Barely perceptible
2	-	Slight
3	-	Moderate
4	-	Strong
5	-	Very strong

(Half score is used when the observer is undecided)

- **Odour Persistence:** It is term used to describe the rate at which an odour's perceived intensity decreases as the odour is diluted. It can be represented as a 'Dose-Response' function, a relationship of odour concentration and odour intensity.
- **Hedonic Tone:** Hedonic tone is a measure of the pleasantness or unpleasantness of an Odour.
- **Odour Character:** Odour character or quality is the property to identify an odour and differentiates it from another odour of equal intensity.
- **Annoyance:** It is defined as interference with comfortable enjoyment of life and property.

## 6.2 Odour Measurement

An odour emission often consists of a complex mixture of many odorous compounds. Analytical monitoring of individual chemical compounds present in such odour is usually not practical. As a result, odour sensory methods, instead of instrumental methods, are normally used to measure such odour. Odour sensory methods are available to monitor odour both from source emissions and in the ambient air. These two diverse circumstances require different approaches

for measuring odour. The collection of odour samples is more easily accomplished for a source emission than for an odour in the ambient air. Also, due to atmospheric dilution, the odour in the ambient air is usually much lower in intensity than it is at source. Thus the sensitivity of the odour sensory method must be significantly greater for measuring ambient odour than for source odour emissions.

For known compounds, the Odour strength can be reliably estimated by measuring the concentration of the chemical, while, for mixtures of unknown substances, sensory method is preferred.

Measurement of odour is standardized for source emission air samples and for ambient air at the property line and in the community. Therefore, three basic odour limits may be incorporated for compliance determining criteria:

1. Ambient odour concentration limits
2. Ambient odour intensity limits
3. Source emission odour concentration limits

Measuring odour can be accomplished in several ways: **instrumental methods / chemical analysis, electronic methods and sensory test methods / olfactometry.**

### **6.2.1 Instrumental methods**

Instrumental methods have relied mainly on the application of gas chromatography (GC), including gas chromatography-mass spectrometry (GC-MS), since this mature separation technology is capable of the efficient separation required for analysis of complex mixtures of odour. In gas chromatography a mixture of volatile substances is injected into a column, which separates the compounds based on their relative vapour pressures and polarities. The compounds are then detected as peaks, which have specific retention times and peak areas, which can be used for qualitative and quantitative determinations, respectively.

### **6.2.2 Sensory methods (Olfactometry)**

Accurate measurement of odorous compounds and their impact have been challenging because these compounds possess widely varying physical and chemical properties and are present at concentrations ranging from high parts-per-million (ppm) to low parts-per-billion (ppb). Furthermore, each odorant has a unique odour and odour detection threshold which means that compounds, even if present at the same concentration, may have markedly different odour impacts.

The sensory methods used for measuring odour level include:

- Static dilution olfactometry
- Dynamic dilution olfactometry
  - free choice
  - forced choice

**(a) Static Dilution Olfactometry**

In Static dilution a sample of odorous gas is diluted in 100 ml glass syringe at various dilution levels. The diluted samples are expelled into the nostrils of the panelists. The odour detection threshold is determined graphically from the dilution levels and panellist response data. A panel of eight panellists is preferred

The American Society for Testing and Materials (ASTM D-1391) static dilution / syringe method was developed in 1978 and was withdrawn by the ASTM E-18 Committee on March 29, 1986, however, the procedure is still in use, principally in the USA.

**(b) Dynamic Dilution Olfactometry**

A dynamic olfactometer provides a continuous and constant diluted odour stimulus by mixing controlled flows of sample and odourless air. With dynamic methods, larger samples are used and dilutions are presented at more reproducible flow rates and for longer duration for panellists to evaluate. The presentation of odorous sample dilutions to panellists and their responses depend on three sensory effects: **judgment criterion, anticipation and adaptation.** The judgment criterion determines how the panellist is to response when asked whether or not an odour is sensed. This is the case particularly when a single stimulus is presented and a yes or no answer is requested as to the sensation of odour. The anticipation effect is a tendency to expect an odour to occur when odourless or weak samples are consecutively presented. The adaptation effect is a temporary loss of sensitivity after smelling an odour. When a weak odour is detected initially, the same odour may not be detected again after smelling a stronger odour unless the panellist has had sufficient time to recover his or her olfactory sense.

**7.0 ODOUR CONTROL TECHNOLOGIES**

Odour control depends on type of sources and is discussed below:

**7.1. Odour Control from Area Sources**

For large area sources following methods can be used to reduce odour complaints.

**i) Excluding development close to the site**

Development close to the site is to be excluded. A reasonable “buffer zone” around the area sources has to be determined. The actual size of the zone depends upon a number of factors, including the size of the area from which odour emanates, the intensity of the odour being emitted, the duration and frequency of the odour emissions, the actual process being undertaken, the topography of the site, the weather conditions that prevails at the site. Green belt development in the buffer zone may help at least partially to mitigate / obfuscate the odour.

ii) **Ensuring that the operation is carried out under the best management practices**

Best management practices (BMP) vary depending upon the industry producing the odour. For all new developments, BMPs starts with the site selection and the building of the facilities.

iii) **Nozzles, sprayers and atomizers that spray ultra-fine particles of water or chemicals can be used along the boundary lines of area sources to suppress odours.**

Rotary atomizer is one such technique widely recommended for effective control of odour in case of area sources. The Atomizer uses centrifugal action by a spinning inner mesh to force droplets on to an outer mesh which "cuts" the water into atoms (Figure 4). The rotary atomizer produces millions of microscopic droplets of water -- up to 238 billion from single little droplets that are thinner than a human hair and a fine spray which covers up to 30 metres. This creates a fine mist, which is more effective with minimal use of water and electricity. A typical installation of rotary atomizer is shown in Figure 5.

There are a large number of chemicals and proprietary products that claim to reduce odour when they are applied to area sources. Atmospheric odour that are contained in a restricted area can be oxidized by atomization of the chlorine dioxide. Odour from sources such as holding ponds, lagoons, and sewage pre or post treatment effluent can be controlled by atomized spray of chlorine dioxide.

To reduce odour, chemicals have to be applied over very large area, the cost of materials and labour would be very high. The large quantity of these compounds required could cause pollution. The spray / atomizer techniques are used to conceal / mask odour also from building and fugitive sources.

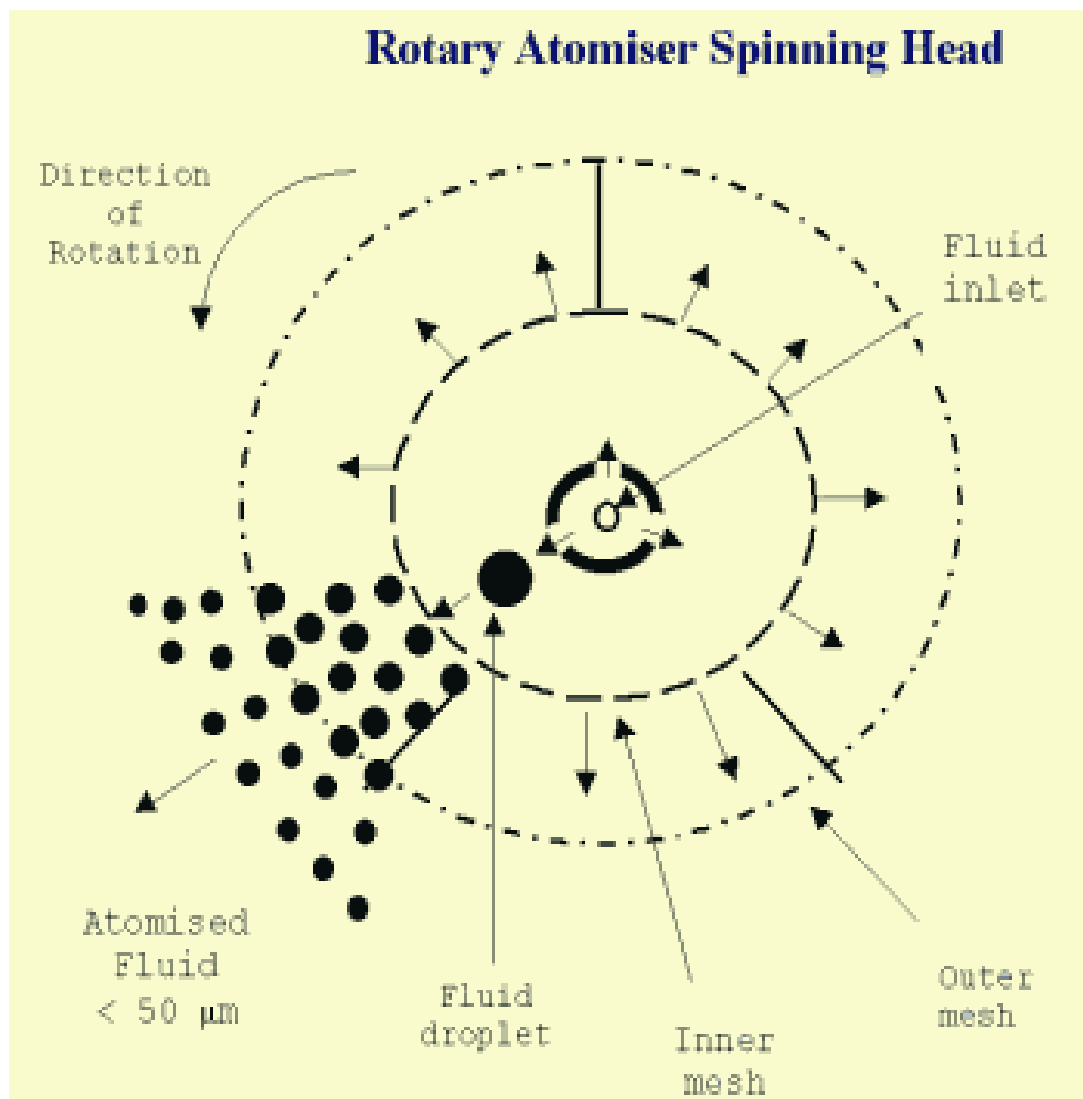

**Figure 2. Working of a rotary atomizer**



**Figure 3. A typical atomizer installation for odour control**

## **7.2 Odour Control from Point Sources**

In case of point sources such as that of industries, the odour-causing gas stream can be collected through piping and ventilation system and made available for treatment. Dispersion method is the simplest of the methods that can be adopted for odour abatement. This is nothing but to release odorous gases from tall stack. It results in normal dispersion in the atmosphere and consequent decrease in ground-level concentration below the threshold value. Dispersal by stacks requires careful consideration of the location & meteorological parameters, etc. In general, dispersion of odour emissions via chimneys is not a recommended method.

An array of treatment technologies is available for control of odour from gas streams collected through process ventilation systems. These include :

- i) Mist filtration
- ii) Thermal oxidation/ Incineration
- iii) Catalytic oxidation
- iv) Biofiltration
- v) Adsorption
- vi) Wet scrubbing/Absorption
- vii) Chemical treatment
- viii) Irradiation

- ix) Masking
- x) Condensation
- xi) Green belt development

The choice of the technology is often influenced by the following factors:

- The volume of gas (or vapor) being produced and its flow rate
- The chemical composition of the mixture causing the odour
- The temperature
- The water content of the stream

### **7.2.1 Mist Filtration**

While gases cause most odour, problem may also result from aerosols in the fumes. Odorous air streams frequently contain high concentration of moisture. If the vapour discharge can be cooled below 40°C, a substantial quantity of the water vapour will condense thereby reducing the volume of gases to be incinerated. Mist filters can be used for this purpose. Mist filters can also remove solids and liquids from gas stream. If the odour is caused by these particles, then it will result in odour reduction also.

### **7.2.2 Incineration**

Incineration is the oxidation of the odour into carbon dioxide and water by the combustion of the odour with fuel and air. The reaction takes place at temperatures ranging from 750°C to 850°C. This is generally above the auto-ignition temperature of most solvents and other VOCs and is a reflection of the heat required to maintain the reaction at dilute concentrations with additional process heat losses. In this regime, the destruction efficiency is almost 100%, assuming adequate oxygen supply. In some cases, other compounds may be formed depending on the mixture of fuel and air used, the flame temperature and the composition of the odour. These compounds may include carbon monoxide, oxides of nitrogen and sulfur oxides.

### **7.2.3 Catalytic oxidation**

Catalytic oxidation reaction can be forced to proceed at much lower temperatures (e.g. 200°C) in the presence of a catalyst (Figure 6). Thus, the advantage of this process over thermal oxidation is the reduction in required energy input. Catalytic systems are therefore more favorable where auto-thermal operation is not practical and heat cannot be economically used elsewhere.

A number of transition and precious metal catalysts can be used in catalytic oxidizer to destroy various VOCs over a wide range of process conditions.

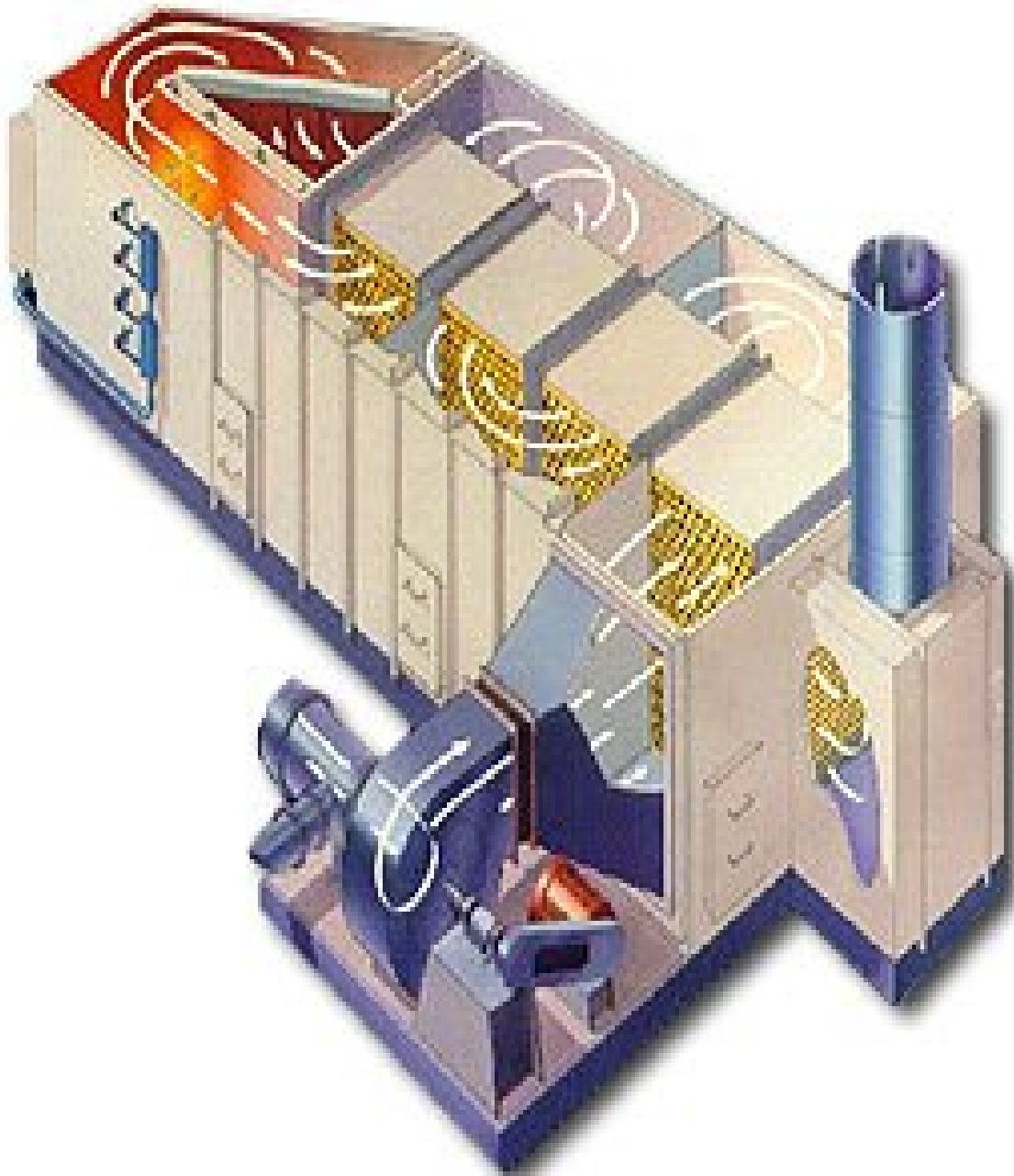

**Figure 4. A catalytic oxidizer system**

#### **7.2.4 Bio-filtration**

This method is becoming an acceptable and successful way of reducing odours from biological process. Bio-filtration is a natural process that occurs in the soil that has been adopted for commercial use. Bio-filters contain micro-organisms that break down VOC's and oxidize inorganic gases and vapours into non-malodorous compounds such as water and CO<sub>2</sub>. The bacteria grow on inert supports, allowing intimate contact between the odorous gases and the bacteria. The process is self-sustaining. Bio-filters can be constructed using various materials such as compost, straw, wood chips, peat, soil, and other inexpensive biologically active materials. Two typical arrangements of bio-filters for odour control are shown in Figure 7.

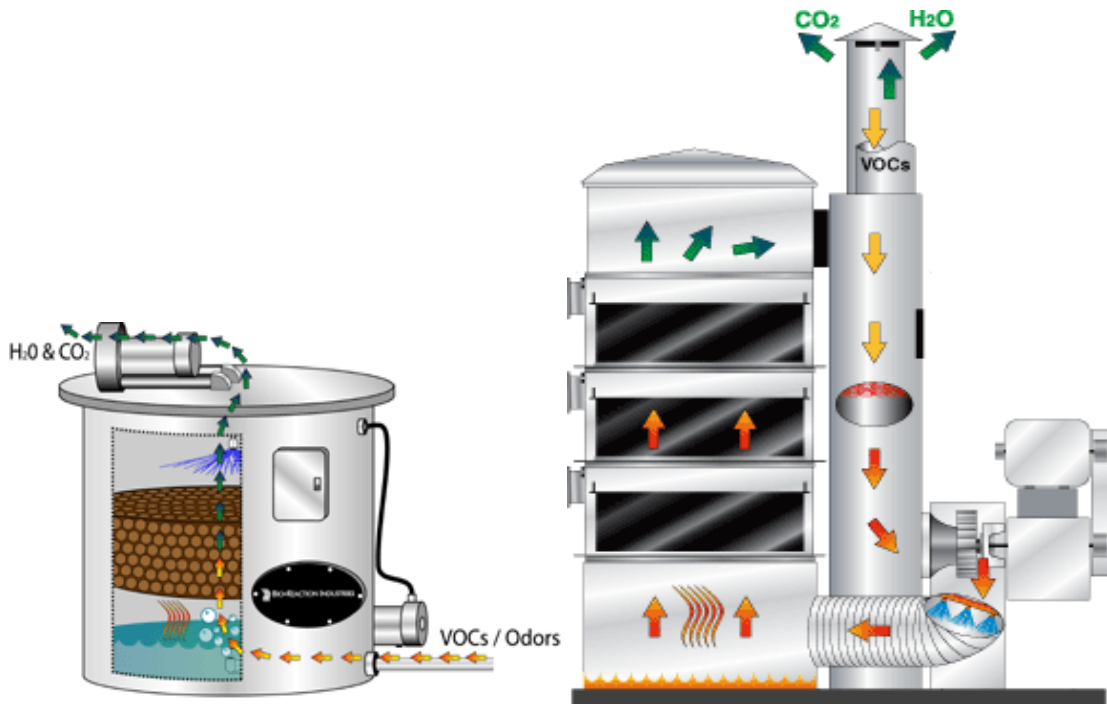

**Figure 5. Bio-filters for odour control**

Another type of bio-filter is the soil-bed filter. Here the odorous gas stream is allowed to flow through a porous soil with a typical depth of 60 cm. The bacteria in the soil are responsible for the destruction of the odorous compounds.

### 7.2.5 Adsorption

A method that is suitable for controlling odorous substances, even at low concentrations is adsorption on to activated carbon. However, the contaminated air stream must be free from dusts and particulates that might clog the carbon particles. Regeneration of carbon for re-use will produce either waste water, which will require further treatment before disposal, or a concentrated vapour stream, which can be incinerated more cheaply than the original air stream.

There are also systems that use activated alumina impregnated with potassium permanganate for adsorption. The alumina absorbs the odorous substances so that the permanganate can oxidize them, usually to carbon dioxide, water, nitrogen and sulfur dioxide, depending on their composition. The alumina bed is replaced progressively as the permanganate is exhausted. This has an advantage over carbon because no further treatment is needed; and may offset the cost of alumina.

### 7.2.6 Wet scrubbing/ Absorption

Wet scrubbing of gases to remove odour involve either absorption in a suitable solvent or chemical treatment with a suitable reagent. It is important that hot, moist streams are cooled before they contact scrubbing solutions. If this is not done the scrubbing solution will be heated and become less efficient and the scrubbing medium will become diluted from condensation of water vapour.

Wet scrubbing or absorption systems can be either **venturi system or packed tower system**. **Venturi systems** are co-current scrubbers that accelerate the gas stream into a high density liquor spray. The aqueous droplets then impinge or impact at high relative velocity with solids in the gas stream. The resulting conglomerated particle is then separated from the gas stream in a disengagement tower by virtue of inertial forces. The high density spray also provides reasonable mass transfer to the absorption of gaseous contaminants. **Packed Towers** are typically counter current scrubbers that utilize high surface area media as a contact zone for the gas stream with suitable scrubbing liquor. The media facilitates high efficiency mass transfer to provide >99.9% removal of gaseous contaminants.

When odour is caused by the presence of unsaturated organic compounds, it may be necessary to use an oxidizing agent such as chlorine, diluted sulfuric acid and sodium hydroxide to treat odour.

Absorption is applicable when the odorous gases are soluble or emulsifiable in a liquid or react chemically in solution. Wet scrubbing is a useful process to handle acid gas streams, ammonia or streams with solids that might foul other equipment. It has been suggested that liquid scrubbing becomes economically attractive compared to incineration and adsorption on activated carbon when the volume of odorous gas to be treated is greater than 5000 cubic meters per hour.

### 7.2.7 Chemical treatment

Injecting controlled quantities of chemicals such as chlorine or hydrogen peroxide into process-gas stream can control odour. Similarly, unlike various other “odour control” treatments, chlorine dioxide will destroy the odour at source. Chlorine dioxide is several times more effective than chlorine and other commonly used treatments, and will not form any hazardous by products, such as chlorinated organic, which can cause more problems than the original odour itself.

Odours arising from water bodies can generally be eliminated by adding chlorine dioxide solution directly to the odoriferous fluid. The first action of chlorine dioxide is to rapidly oxidize the vapour gases dissolved in the fluid to their oxide form. As the dissolved gases are oxidized the amount of chlorine dioxide will increase. The next action of chlorine dioxide is the oxidation of small molecular material, and, as the amount of chlorine dioxide increases further, the larger molecules and compounds are oxidized.

Due to this versatility, chlorine dioxide can be used in all aspects of odour control process, from air scrubbers and wastewater treatment. However, Hydrogen Peroxide may be preferred over Chlorine Dioxide due to toxicity of organo-chlorides.

## *Odour Control with Chlorine Dioxide and Hydrogen Peroxide*

### Odour Control with Chlorine Dioxide

#### a) **Chemistry of Odour Reduction**

- Can react to go to chlorite or chloride as follows:



#### b) **Odour Removal Reaction**

### Inorganic

#### *Hydrogen Sulphide*



- pH 5-9, min 2.7 ppm of  $\text{ClO}_2$  oxidises 1.0 ppm of sulfide.
- No colloidal sulfur formed.

### Organic

Reactions are slower and proceed in stepwise fashion.

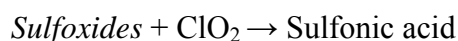
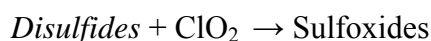

Overall reaction pH 5-9, 4.5 ppm of  $\text{ClO}_2$  oxidises 1 ppm of Mercaptan.

#### c) **Chlorine Dioxide – Generation Aspects**

Chlorine Dioxide is produced by chemical reaction in a reaction vessel commonly called a 'generator'

Two common methods used in 95% of cases throughout the world:

##### a) Acid - Chlorite Method



##### b) Chlorine – Chlorite Method

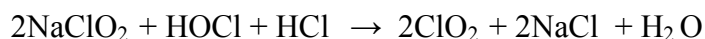

BelloZen acid – chlorite method is simplest, safest and most accurate.

(Australia has 35 such operating system, Italy has 1000, Germany has 500 and many more in France and rest of the World).

### Odour Control with Hydrogen Peroxide

#### a) Chemistry of Odour Reduction

- It is supplied as a liquid solution of 50% w/w concentration.
- It is very strong oxidant with high E° potential.
- Easily dosed and controlled into effluent or into air scrubbers.
- Environmentally friendly by-products i.e. water and oxygen.
- Hydrogen Peroxide has no chemical odour of its own. Thus, overdosing will not cause a chemical odour breakthrough but will only increase the cost.

#### b) Odour Removal Reaction

##### Inorganic

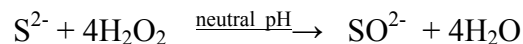
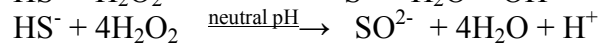
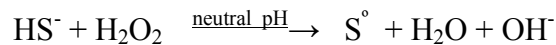
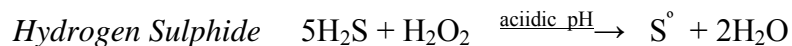

Acidic conditions consume less peroxide but require larger scrubbing area due to lower solubility of sulfides. It may be advantageous if the gas contains large amount of CO<sub>2</sub>.

Alkaline pH = 10-11 conditions give fast reaction with removal efficiencies 97-99.9%.

##### Organic

Reactions proceed in stepwise fashion.

##### *Mercaptans RSH*

First, dissolving

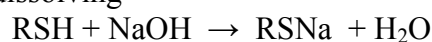

Next, oxidation

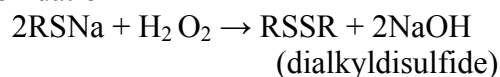

Reaction is very fast and can occur in the scrubber.

RSSR is odorous and must be oxidized further.



(The disulfide has very low solubility in water and thus the reaction is slow).

### 7.2.8 Irradiation / Neutrapol

Basically ultra-violet radiation forms ozone. Ozone, is a very re-active form of oxygen, it exchanges electrons with target molecules. Ultra-violet applications for waste purification require generally high capital expenditure to form chambers to hold gases requiring treatment for about 3-4 minutes. If the rate of gas flow is variable, the treatment may be ineffective.

Now a days, **neutrapol** is used instead of ozone which is harmless and non-toxic. Neutrapol is a monomer. It forms long chain molecules which carry a positive charge. Generally, the molecules of target gases and surfaces are negatively charged. Since unlike charges attract, the Neutrapol molecules is attached to the target molecules. Thus, unlike the traditional method of using a perfume to overpower an unpleasant odour with a pleasant smell, a true chemical change takes place.

#### Deodorisation Mechanism for Varoius Gases

- a) **Ammonia type:** The volatile, odorous elements are combined with an organic acid radical to form a non- odorous compound which is non-volatile.



- b) **Hydrogen Sulfide:** The hydrogen sulfide is converted into a complex organic sodium salt incorporating sodium metabysulfide, resulting in a non-volatile, non-odorous and non-poisonous compound.

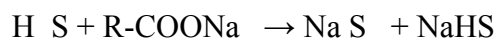

- c) **Methyl Mercaptans:** The mercapatns are very unpleasant and are commonly produced by rotted proteins (e.g. smells of rotten fish, public urinals)



The gases are converted to a complex organic salt.

Neutrapol is distinguished from other neutralizers by its ability to deodorize not just one type of gas but a wide range of gases, acidic, neutral and alkaline, automatically and simultaneously.

It can be used in a number of ways: add Neutrapol to recyclable water in scrubber systems; dilute and surface spray; use during the transportation and/or loading sludge; use during cleaning; continually drip Neutrapol into waste water

by using an automatic dripping system or periodically pour into waste water daily.

### **7.2.9 Condensation**

Condensation is the process of converting a gas or vapour to liquid. Any gas can be reduced to a liquid by sufficiently lowering its temperature and / or increasing pressure. The most common approach is to reduce the temperature of the gas stream, since increasing the pressure of a gas can be expensive.

Condensers are simple, relatively inexpensive devices that normally use water or air to cool and condense a vapour stream. Since these devices are usually not required or capable of reaching low temperatures (below 100°F), high removal efficiencies of most gaseous pollutants are not obtained unless the vapours will condense at high temperatures. Condensers are typically used as pretreatment devices in order to reduce the cost of the control system. They can be used ahead of adsorbers, absorbers and incinerators to reduce the total gas volume to be treated.

### **7.2.10 Green Belt Development**

Green belts are used to form a surface capable of sorbing and forming sinks for odorous gases. Leaves with their vast area in a tree crown, sorbs pollutants on their surface, thus effectively reduce their concentrations in the ambient air and source emissions.

While making choice of plant species for green belts, weightage has to be given to the natural factor of bio-climate.

Odour can be reduced by developing green belt for counteracting smell, counteracting chemicals.

- Plants which counteract odour are
  - Bushes with mild but active fragrance.
  - Acacia farnesiana (Mexican plant): It is a type of bush with yellow coloured fragrant flowers. It does not have rich canopy but very effective for counteracting smell. Its limitation is seasonality and thorny nature.
  - Melaleuca species: It has sweet fragrance and thin canopy in India.
  - Pine, Cedar, Junipers: They have excellent canopy and protection. Its limitation is site specificity.
  - Eucalyptus: It can be used as very good belt and can also be used as per odour source. Its limitation is site specificity and height in the urban neighbourhood.

- Hedges, Herbs (Tulsi, Turmeric etc.) can also be used for counteracting odour.
- Vetiver : This plant is a king of perfumes for inactivating other odours. It affects the nervous system and relieves fatigue. It is used as key species in aromatherapy.
- Plants which tolerate pollution
  - Nerium (Kaner): This plant may or may not have a thick canopy but has excellent results with vehicular pollution and experimented at National Botanical Research Institute, Lucknow.
  - Acacia auriculiformis etc.

Other than these, plants which are used to form green belt - Bamboo, Pongamia pininata, Neem and Casuarina etc.

## **8.0 STUDIES CARRIED OUT IN INDIA**

### **8.1 Study Carried Out in Andhra Pradesh Paper Mills Limited**

The present production capacity of Andhra Pradesh Paper Mills Limited is 1,00,000 TPA. The Andhra Pradesh Paper Mills Limited has installed a Non Condensable Gases Handling and Incineration system including collection, transportation and incineration to minimise odour.

#### **Non Condensable Gases (NCG)**

- Constituents of NCG are Hydrogen Sulphide, Methyl Mercaptans, Dimethyl Sulphide and Dimethyl Disulphide.
- Non Condensable Gases are normally released in Pulp and Paper industry from pulping and chemical recovery sections.
- These gases are classified into strong NCG and Weak NCG.
- Handling of NCG includes identifying the sources, making measurements and installing suitable system for collection and burning.

#### **Sources of Strong NCG**

- The main source of strong NCG is cooking. NCG are released from blow tanks during blowing and also along with de-gassing vapours.
- Strong NCG are released continuously from evaporator plant.

### Sources of Weak NCG

- Brown Stock Washing section
- Tank vents (black liquor, smelt dissolving, condensate)
- Other tanks (white liquor, foam tanks, etc.)

### Measurement of NCG

Detailed analysis was carried out for Hydrogen Sulphide, Methyl Mercapatan, Dimethyl Sulphide & Dimethyl disulphide and is presented below:

Component	Total strong NCG (dry) in %
Hydrogen Sulphide	1.08
Methyl Mercapatan	2.29
Dimethyl Sulphide	2.09
Dimethyl Disulphide	0.92
Air	92.84

NCG Flow was 14.6 Nm<sup>3</sup>/T of Pulp (Avg); and 39.2 Nm<sup>3</sup>/T of Pulp (Max)

### Details of the NCG Handling System Installed

#### Evaporators

A shell and tube condenser is installed for removal of water vapour before incineration.

#### Digesters

- Open type condenser is closed in waste heat recovery system.
- NCG from digester degassing is collected.
- Ejectors are installed for transportation of NCG from evaporators and digesters.
- Droplet separators are installed for removal of water particles prior to incineration.

## 8.2 Study Carried out by Central Pulp & Paper Research Institute, Saharanpur

### *Odour Problem and Sources of Emissions in Pulp & Paper Industry*

- Paper industry uses various chemicals which contribute to odorous emissions.
- The release of sulfurous compounds i.e. Non Condensable Gases (NCG's) are the major sources of odour & their presence in atmosphere causes odour.

The main NCG released during pulping process are given below:

Digester	-	CH <sub>3</sub> SH, CH <sub>3</sub> OH
Black Liquor Storage Tank	-	H <sub>2</sub> S, CH <sub>3</sub> SH, CH <sub>3</sub> ' <sub>2</sub> S
Evaporator	-	H <sub>2</sub> S, CH <sub>3</sub> ' <sub>2</sub> S <sub>2</sub> , CH <sub>3</sub> ' <sub>2</sub> S, CH <sub>3</sub> OH
Recovery Boiler	-	H <sub>2</sub> S CH <sub>3</sub> SH, CH <sub>3</sub> ' <sub>2</sub> S
Smelt Dissolving Tank	-	H <sub>2</sub> S, CH <sub>3</sub> SH
Lime Kiln	-	H <sub>2</sub> S, CH <sub>3</sub> SH

### **Generation of NCG in Fibrous Raw Materials used by Pulp & Paper Industry**

NCG	Digester Relief	Digester Blow
Methyl Mercaptan (CH <sub>3</sub> SH)	0.2-15 ppm	15-1,500 ppm
Dimethyl Sulphide (CH <sub>3</sub> ) <sub>2</sub> S	10-2,000 ppm	50-12,000 ppm
Methanol (CH <sub>3</sub> OH)	15-1,000 ppm	50-10,000 ppm

### **Generation of NCG in Pulp & Paper Industry**

Sources	Methyl Mercaptan (CH <sub>3</sub> SH) in ppm	Dimethyl Sulphide (CH <sub>3</sub> ) <sub>2</sub> S in ppm	Methanol (CH <sub>3</sub> OH) in ppm
Digester Relief	500-3,000	100-8,000	~ 1,000
Digester Blow	1,000-10,000	2,000-20,000	2,000-8,000
Evaporator Vent	2,000-45,000	1,000-50,000	2,000-25,000

### 8.3 Study Carried Out in Daurala Sugar & Distillery Factory

#### Odour Problem and Sources of Emissions

- Typical compounds generating odour in sugar industry are acetic acid, ethyl alcohol / butyl alcohol, bacterial decomposition of organic matter (stale cane smell) & bacterial decomposition of sulphur compounds (H<sub>2</sub>S).
- Causes of odour are stale cane, bad mill sanitation, bacterial growth in the interconnecting pipes & unattended drains etc.

#### Remedial Measures:

- Better cane management to avoid staling of sugar
- Use of mill sanitation bio-cides to minimize the growth of aerobic / anaerobic micro-organisms
- Steaming of major pipe lines
- Proper cleaning of drains
- Regular use of bleaching powder in the drains to avoid growth of sulphur decomposing micro-organisms to control H<sub>2</sub>S generation.

#### Advantages:

- Odour reduction
- Better recovery
- Lower overall losses
- Preservation of juice purity from primary to mixed juices ultimately resulting in lower losses

#### Odour and smell in sugar factories

#### Result showing operational data of Daurala Sugar Factory

Crushing Season	Pol (% Cane)	Recovery	Reduction Purity Drop (Primary Juice to Mixed Juice)
96-97	12.64	10.46	1.86
97-98	12.77	10.69	1.81
98-99	12.18	10.12	1.63
99-00	12.342	10.47	1.59
00-01	13.12	11.17	1.52
01-02	12.83	10.83	1.47
02-03	12.67	10.60	1.34

## **Distillery factories:**

### **Odour Problem and Sources of Emissions**

- Typical odour compounds in distillery are alcohol, iso amyl & iso butyl alcohol (fusel oils), acetic acid & H<sub>2</sub>S.
- Causes of odour are bad management of fermentation house, long retention of fermented wash, unattended drains & ETP (H<sub>2</sub>S from primary treatment of spent wash ammonia from secondary biological treatment of spent wash & smell from bio-composting plant).

### **Remedial Measures:**

- Better house keeping by regular steaming of all fermentation equipments
- Regular steaming of all fermentation equipment.
- Use of efficient bio-cides to control bacterial contamination.
- Control of temperature during fermentation to avoid in-activation / killing of yeast.
- Avoiding staling of fermented wash.
- Regular use of bleaching powder in the drains to avoid generation of putrefying micro-organisms.

### **Advantages:**

- Comparative reduction in odour
- Better fermentation efficiency
- Better recovery

### **Control of smell emitting from effluent treatment plant**

#### **a. Primary treatment (bio methanation)**

- Selection of technology-monophasic / di-phasic
- Efficient operation of ETP.
- Preventive maintenance of gas lines & utilization systems

#### **b. Secondary treatment (activated sludge process)**

- Ammoniacal smell emitting from the process can not be controlled since it is associated with the process.

**c. Separation & disposal of sludge**

- To be done in most appropriate manner to avoid putrefied smell arising from decomposed spent Yeast.

**Comparison of different control methods:**

Sl. No.	Odour Control Method	Suitable for inlet concentration	Equipment cost	Operating Cost
1.	Absorption	% Level	Low	Low
2.	Adsorption	ppm	Medium	Medium
3.	Incineration	ppm	High	High
4.	Biological methods	ppm	Low	Low

**8.4 Case Study – Odour Control in Domestic Solid Waste Treatment Plant, Chennai**

A decentralized integrated bio-mechanization plant has been implemented near Koyambedu Market in Chennai to utilize vegetable, fruit, flower wastes. The plant generates about 2000 m<sup>3</sup> of biogas and 4 tons of bio-fertilizer from 30 tons of degradable wastes. The biogas is being converted into electricity using biogas engine and connected to Tamil Nadu Electricity Board power grid. For the first time odour control system with bio-filter is implemented with contributions by Ministry of Non-Convention Energy Sources, Govt. of India and Chennai Metropolitan Development Authority.

The main sources of odour are from waste storage yard, collection sump, sorting area and minceration unit. The air from these areas is collected through pre-suction pipes and connected to a blower. The inlet of the pipe is covered with anticorrosion mesh to avoid flies and solid particle entry into the pipe leading to bio filter. A bio filter is developed using wooden chips as media. Water is sprinkled occasionally to keep the media under wet condition.

**9.0 LEGISLATIONS, STANDARDS AND REGULATIONS FOR MASUREMENT OF ODOUR**

Several countries have developed and adopted Legislations for measurement of odour, an overview of which is presented below:

**Australia**

In Australia the states have the responsibility for setting air quality policies for odour.

### ***Australia – New South Wales***

The Environmental Protection Agency of New South Wales issued a draft policy on odour in January 2000:

- NSW EPA, *Assessment and Management of Odour from Stationary Sources in NSW, Draft, Sydney, January 2001.*

The policy states a general set of odour impact criteria:

1. *Ground level concentration (glc) for individual odorous pollutants*
2. *Odour performance criteria for complex mixtures of odours*

A level of 7 OU/m<sup>3</sup> is deemed to be the appropriate exposure level for a single affected residence. For larger population, in which there will be a greater sensitivities to odour, acceptable odour is defined to be 2 OU/m<sup>3</sup>.

### ***Australia – Victoria***

Odour prevention and control has been formalised in State Environment Protection Policies (SEPP's):

- SEPP AAQ : Ambient Air Quality
- SEPP AQM : Air Quality Management

For known compounds, the Odour strength of the emissions can be reliably estimated by measuring the concentration of the chemical.

For mixtures of unknown substances, odour strengths are estimated by a panel of trained human noses using the EPA's standard analytical procedure, No. B2 Odour Dynamic Olfactometry, known as B2 method. Odour strengths are calibrated based on the principle that 1 OU/m<sup>3</sup> is the level of odour which can be detected by the average human nose.

### ***Australia – Queensland***

The main focus for odour is on cattle feedlots and developed the Queensland Government Guidelines for Establishment and Operation of Cattle Feedlots, 1989.

Recently an air quality criterion of C98, 1hr = 10 OU/m<sup>3</sup> was used as a condition in a licence for a new piggery in Queensland.

### **Belgium**

Currently a policy review is under way to establish a concerted policy on odour in Flanders, the Northern part of Belgium. The Flemish Environmental Policy Plan 2002-2006 contains an initiative to define odour exposure standards for 16 sectors of economic activity, focussing on five pilot sectors:

- Pig farms
- Slaughterhouses

- Paint application
- Waste water treatment plant
- Textile plants

The techniques rely on field panels that determine the maximum distance at which the source can be detected. This distance and the weather conditions are used in a Gaussian dispersion model to estimate the emission of the source in ‘sniffing units’.

The concept of ‘sniffing units’ is similar in use to odour units, but measured in the field rather than in the laboratory, using stack samples, as is done for odour units.

### **Canada**

In Canada the responsibility for odour regulations lies with the provinces. Various provinces have their own odour regulation or policy.

Ontario has a regulation since 1976 titled Agricultural Code of Practice that setback distances to livestock facilities.

Manitoba also uses a schedule of setback distances for livestock units.

In Alberta an ambient air quality guidance for H<sub>2</sub>S of 10 ppb/v as a one hour average is applied for the specific purpose of odour impact management. This would amount to 20 ou/m<sup>3</sup> on the basis of smell of H<sub>2</sub>S only, with an odour threshold of 0.5 ppb/v. In addition an Ammonia criterion of 2 ppm/v applies.

### **Denmark**

In Denmark an exposure criterion is used which stated that the ground level concentration should not exceed 5 to 10 ou/m<sup>3</sup>, depending on the location (residential or non-residential), at a 99-percentile, with an averaging time of 1 minute.

### **Germany**

The method VDI3940, (1993) *Determination of Odorants in Ambient Air by Field Inspections* is applied to determine licensing applications.

The exposure criteria for different land use are:

- < 10% ‘odour hours’ in residential areas
- < 15% ‘odour hours’ in industrial areas

However, in most cases, a technical guidance is applied, that provides detailed advice on the design and operation of the activity of the applicant. An example of such guideline is:

- VDI3475 Part 1 *Emission reduction for biological waste treatment units*  
– *Collection and Composting for units with a capacity = 0.75 Mg/h.*

- VDI3471:1986 Emission Control ---- Livestock management – Pigs
- VDI3471:1986 Emission Control ---- Livestock management – Hens
- VDI3473:1994 Part 1 (draft) Emission Control ---- Livestock farming – Cattle

In addition to technical guidance, the technical standard, VDI3471:1986, contains a graph providing setback distances, for pig units of different sizes.

### **Japan**

Japan has a long track record in regulating odour. The Japanese regulation is based on a specific method of olfactometry, based on triangular testing yields a result for n-butanol of 38 ppb/v, which is compatible with the accepted reference value for the European odour units of 40 ppb/v.

The Japanese Offensive Odour Control Law expresses odour intensity as the Odour Index, which is:

$$\text{Odour Index} = 10 \text{ Log}(\text{Odour Unit})$$

The standard is based on the premise that an Odour Index associated with an odour intensity scale value of 2.5-3.5 is deemed acceptable. The intensity scale used is:

- 0 – Not perceptible
- 1 – Faint smell (detectable)
- 2 – Weakly quality perceptible (recognition)
- 3 – Easily quality perceptible
- 4 – strong
- 5 – very strong

### **New Zealand**

The Ministry of Environment of New Zealand, quantitative air quality criteria are suggested, of 5 to 10 ou/m<sup>3</sup> at percentile values of 99.5 to 99.9 (<http://www.mfe.govt.nz/>).

### **The Netherlands**

Air quality criteria were defined, as a limit for the 1-hr average odour concentration that could not exceeded more than a defined percentage of annual hrs. The limits were proposed and later implemented in hundreds of license applications:

- C99.5, 1- hr < 0.5 ou/m<sup>3</sup> for applications for new installations (sources), not to be exceeded at the nearest ‘odour sensitive location’

- C98, 1-hr < 0.5 ou/m<sup>3</sup> for applications for existing installations (sources) or expansion of such installations, not to be exceeded at the nearest 'odour sensitive location'
- C95, 1-hr < 0.5 ou/m<sup>3</sup> for isolated residential houses located on industrial estates
- C99.9, 1-hr < 0.5 ou/m<sup>3</sup> for discontinuous, incidental sources, not to be exceeded at the nearest 'odour sensitive location'

As result of this guideline, a standard for olfactometry, which was implemented in NVN2820:1993. Laboratories were then required to become accredited and the measurements were included as a method for impact assessment for licensing purposes and enforcement. (Note: The value of 0.5 ou/m<sup>3</sup>, referenced to 40 ppb/v n-butanol, is equal to 1 gem<sup>3</sup> or Dutch odour unit, that was referenced to 20 ppb/v n-butanol).

## **United Kindom**

### ***Environment Protection Act – Part 1***

Part 1 of the above Act covers two discreet regimes of control:

- IPC – Integrated Pollution and Control for the most complex and polluting processes with emissions to air, land ad water.
- LAAPC – Local authority pollution control for less polluting small processes covering emissions to air only.

### ***IPPC***

The Integrated Pollution, Prevention and Control (IPPC) Directive, as implemented by the Pollution Prevention and Control Regulations 1999 stipulates that offensive odour emissions will be prevented or where that is not practicable, reduced in order to achieve a high level of protection of the environment as a whole.

Some activities currently covered by a waste management licence will fall within IPPC. These include:

- Any installation disposing of hazardous waste and some hazardous waste recovery operations.
- Incinerators
- Disposal of non-hazardous waste by physico-chemical or biological treatment.
- All landfills
- Some sewage treatment works

The enforcing authority, whether it be the Agency or Local Authorities, BAT is used as the basis for setting emission limit values.

## **United States**

In the United States, there is no odour policy at the federal level. A standard exists, generally called the ASTM Syringe method:

- ASTM D 1391 - 57 (1972): *Standard Method for Measurement of Odour in Atmospheres.*

A number of universities have now adopted the method as described in EN13725 'Air quality – Determination of odour concentration by dynamic olfactometry'. These universities are typically involved in research of agricultural livestock odour (Duke University, Iowa State University, the University of Minnesota, Purdue University).

In addition wastewater treatment organisations use this method (Los Angeles County Sanitation District, Minnesota Metropolitan Council).

In agricultural sector, odour complaints are a topical issue. The American Society of Agricultural Engineering published a code of practice:

- ASAE, Control of Manure Odour, Engineering Practice 379.1.

That recommends setback distances to separate livestock units from residents between 800 m for neighbouring residences and 1600 m for residential development.

The State of Minnesota has a feedlot air quality programme, in which the Minnesota Pollution Control Agency is appointed to monitor air quality around feedlot through measurement of H<sub>2</sub>S conc. in air presented below:

- 30 ppb/v H<sub>2</sub>S as a 30 minute average not to be exceeded on more than 2 days in a five day period (this would be at least 60 ou/m<sup>3</sup>, based on an odour threshold for H<sub>2</sub>S of 0.5 ppb/v, not taking into account other odorants).
- 50 ppb/v H<sub>2</sub>S as a 30 minute average not to be exceeded on more than 2 times in a year.

## **General**

The EN 13725 was released in year 2003 and now EN 13725 unifies the odour sampling and testing standards of 18 countries (Austria, Belgium, Denmark, Finland, France, Greece, Germany, Iceland, Ireland, Italy, Luxembourg, Netherlands, Norway, Portugal, Spain, Sweden, Switzerland, and the United Kingdom). Also EN 13725 follows ISO 9000 quality assurance and scientific testing protocols.

The new European standard EN 13725 has been adopted by Australia and New Zealand as AS / NZS 4323:3:2001 (AS, 2001).

In India, Schedule II and Schedule VI (General standards for discharge of effluents) under Environmental (Protection) Rules, 1986 prescribes that all efforts shall be made to remove unpleasant odour as far as practicable. Nonetheless, there are only two industries, wherein industry specific standards under Schedule I of these Rules mandate odour removal. These are the fermentation industries and the natural rubber industries. The standards for many other major odour pollution causing industries such as pulp and paper mills, tanneries, meat processing

industries, bulk drug and pharmaceutical units, food and fruit processing units, dairies and milk plants etc. do not specify odour control.

## 10.0 RECOMMENDATIONS

Major recommendations of the Expert Committee on Odour Pollution and its Control include the following:

- i) The report of the Expert Committee may be adopted as a guideline for odour pollution and its control.
- ii) In order to develop and implement effective control programme on odour pollution, it is necessary to measure odour in a manner that is accurate, precise and acceptable.

The instrumental method may be adopted for known compounds and for mixtures of unknown substances, sensory method is preferred.

The currently accepted method EN 13725: 2003, Forced-Choice presentation, may be standardized and adopted in India also.

- iii) There is a need for generation of data based information on the magnitude of the odorous gases/chemicals at point source as well as in the ambient environment around these sources.
- iv) Ambient standards for odour pollution shall be evolved.
- v) Source specific (point source as well as diffuse source) standard for odour emission shall be evolved for industries such as Pulp & Paper, Fertilizer, Pesticides, Tanneries, Sugar & Distillery, Chemical, Dye & Dye Intermediates, Bulk Drugs & Pharmaceuticals, Landfill and Waste Water Treatment Plant etc.,
- vi) Human resource may be developed with international exposure and assistance to work in the field of odour pollution control.
- vii) All out efforts should be made to operate and maintain treatment plants, air pollution control devices, dump sites, TSDF etc. to achieve optimal reduction in odour pollution.
- viii) Hot spot of odour pollution may be tackled with knowledge and technology presently available in the country.
- ix) Pilot plants / Best Management Practices to control odour pollution may be installed / demonstrated sector wise to display the technology. Such installation may be sponsored and financial assistance provided, if required.

- x) Green belts with suitable species of plants/trees and other physical methods may be adopted for control of odour pollution especially near odour producing industrial processes and waste disposal sites.

## REFERENCES

1. Journal of Indian Association for Environmental Management, Vol 29, No. 1, February, 2002 (ISSN 0970-8480).
2. Elements of Successful Odour/Odour Laws by Charles M. McGinley, Thomas D. Mahin and Richard J. Pope. WEF Odour/VOC 2000 Specialty Conference Cincinnati, OH. 16-19, April, 2000.
3. Industrial Odour Control Manual by Clean Air Society of Australia and New Zealand.
4. CPCB Newsletter on Odour Pollution & its Control.
5. Review of Odour Management in New Zealand. Prepared by Tracy Freeman and Roger Cudmore for the Ministry for the Environment. [www.mfe.govt.nz](http://www.mfe.govt.nz)
6. Air Pollution Engineering Manual, 2<sup>nd</sup> Edition, Air & Water Management Association Edited by Wayne T. Davis.
7. A Review of the Science and Technology of Odour Measurement, prepared for the Air Quality Bureau of the Iowa Department of Natural Resources, by St. Croix Sensory, Inc (30 December, 2003).
8. Odour Regulation and Odour Legislation Overview. ([www.odournet.com/legislation.html](http://www.odournet.com/legislation.html))
9. Guidelines for Developing Greenbelts, Central Pollution Control Board, Programme Objective Series: PROBES/75/1999-2000.
10. Enforceable Permit Odor Limits by Charles M. McGinley, P.E..St. Croix Sensory, Inc.
11. Measuring Composting Odors for Decision Making by Charles M. McGinley, P.E..St. Croix Sensory, Inc. and Michael A. McGinnley, P.E. St. Croix Sensory, Inc.
12. Presentations made by Dr. H. M. Behl, Dy. Director, National Botanical Research Institute, Lucknow on Plants against Odour Pollution.
13. Presentations made by Dr. M. C. Bardiya, Sr. G.M., Duarala Sugar Works on Odour & Smell in Sugar Factories & Distillery Industries.
14. Presentations made by Dr. H. M. Behl, Dy. Director, National Botanical Research Institute, Lucknow on Plants against Odour Pollution

15. Presentations made by Dr. R. A. Pandey, NEERI, Nagpur on Odour Pollution & International Regulations.
16. Presentations made by Dr. S. Rajamani, Head, Deptt. of Environmental Technology, Central Leather Research Institute, Chennai on Odour Control from Tanneries.
17. Presentations made by Shri Hemant Joglekar, National Chemical Laboratory, Pune on Measurement and Control of Sulphurous Odorants.
18. International Union of Environment (IUE) Commission of IULTCS Document on 'Environmental Update on World Leather Sector' Chapter 8, Odour Control in Tannery – May 2006.

**SENSORY METHODS (OLFACTOMETRY)**

*(Industrial Odour Control Manual by Clean Air Society of Australia and New Zealand)*

Accurate measurement of odorous compounds and their impact have been challenging because these compounds possess widely varying physical and chemical properties and are present at concentrations ranging from high parts-per-million (ppm) to low parts-per-billion (ppb). Furthermore, each odorant has a unique odour and odour detection threshold which means that compounds, even if present at the same concentration, may have markedly different odour impacts.

The sensory methods used for measuring odour level include:

- Static dilution olfactometry
- Dynamic dilution olfactometry
  - free choice
  - forced choice

**(a) Static Dilution Olfactometry**

In Static olfactometry, a sample of odorous gas is diluted in 100 ml glass syringe at various dilution levels. The diluted samples are expelled into the nostrils of the panellists. The odour detection threshold is determined graphically from the dilution levels and panellist response data. A panel of eight panellists is preferred.

The American Society for Testing and Materials (ASTM D-1391) static dilution / syringe method was developed in 1978 and was withdrawn by the ASTM E-18 Committee on March 29, 1986, however, the procedure is still in use, principally in the USA.

**(b) Dynamic Dilution Olfactometry**

A dynamic olfactometer provides a continuous and constant diluted odour stimulus by mixing controlled flows of sample and odourless air. With dynamic methods, larger samples are used and dilutions are presented at more reproducible flow rates and for longer duration for panellists to evaluate. The presentation of odorous sample dilutions to panellists and their responses depend on three sensory effects: **judgment criterion**, **anticipation** and **adaptation**. The judgment criterion determines how the panelist is to response when asked whether or not an odour is sensed. This is the case particularly when a single stimulus is presented and a yes or no answer is requested as to the sensation of odour. The anticipation effect is a tendency to expect an odour to occur when odourless or weak samples are consecutively presented. The adaptation effect is a temporary loss of sensitivity after smelling an odour. When a weak odour is detected initially, the same odour may not be detected again after smelling a stronger odour unless the panellist has had sufficient time to recover his or her olfactory sense.

Most of these problems are resolved by adopting a procedure in which a forced-choice multiple stimulus method is combined with a systematic ascending order of odorous sample concentrations (corresponding decrease in dilution).

## ***FREE CHOICE DYNAMIC OLFACTOMETRY***

The dynamic dilution olfactometric procedure principally applied throughout Australia is based on Environment Protection Authority of Victoria Standard Analytical Procedure B1 "Analysis – Dynamic Dilution Olfactometry". The panelist selection process was originally described in American Standard Test Methods (ASTM) Method No. D1391-57 "Standard Method for Measurement of Odour in Atmospheres (Dilution Method)."

These procedures have formed the basis of draft Australian Standards for stationary source emission monitoring.

### **Sample Collection from Stationary Sources**

Odour sampling bags are manufactured from polyester film with a nominal capacity of 15 litres. The sampling bag is enclosed in an airtight plastic drum. Prior to sampling, the moisture content of the exhaust gases is determined. The dilution required to prevent condensation of the sample gas is calculated, and the required volume of odour free diluent air added to the sampling bag. Normally 10 litres of diluent air is required. The stack sampling train is shown in Figure 2.

The sampling probe, constructed from stainless steel or Poly Tetra Fluoro Ethylene (PTFE), contains a 60 $\mu$  m pore size sintered stainless steel filter. The probe inlet is positioned at a distance of one quarter of the stack internal diameter from the wall of the stack. The sampling line (stainless steel or PTFE) connecting the probe to the sampling bag is heated to maintain the temperature of the sample gas above the dew point. The sampling pump is connected to the drum containing the sampling bag. The drum is then evacuated at a rate of 0.5-2.0 l/min. The sample gas volume is recorded by the dry gas meter. When the required volume is collected (normally 2 litres), the sampling bag line is capped in preparation for transport. Sampling bags must not be reused, due to possible adsorption of odorants on the polyester film surface.

The exhaust gas velocity and temperature are also measured to calculate the wet gas flow rate (at 0°C and 101.3 kPa).

### **Sample Collection from Area Sources**

The rate of emission of odour from area sources such as oil / water separators, wastewater treatment lagoons and raw material / product stockpiles is difficult to quantify. The procedure normally used is flux chamber. The chamber is positioned on the area source surface. A source of odour free dilution air is attached to the chamber and set at a low flow rate.

After a period of equilibrium, a sample is collected from the chamber exhaust gases using the procedure described for stationary sources. The results are expressed as odour units per unit time per unit area (O.U. /min m<sup>2</sup>) based on the chamber area exposed to the source surface.

The total source surface area is also measured, and the total source emission rate calculated.

## Odour Panellists

Panellists must previously pass a selection process involving a triangle testing procedure. Solutions of vanillin and methyl salicylate are prepared in benzyl benzoate at the following concentrations:

Set	Concentration (%/w)
1	1
2	0.9
3	0.8
4	0.7
5	0.6
6	0.5

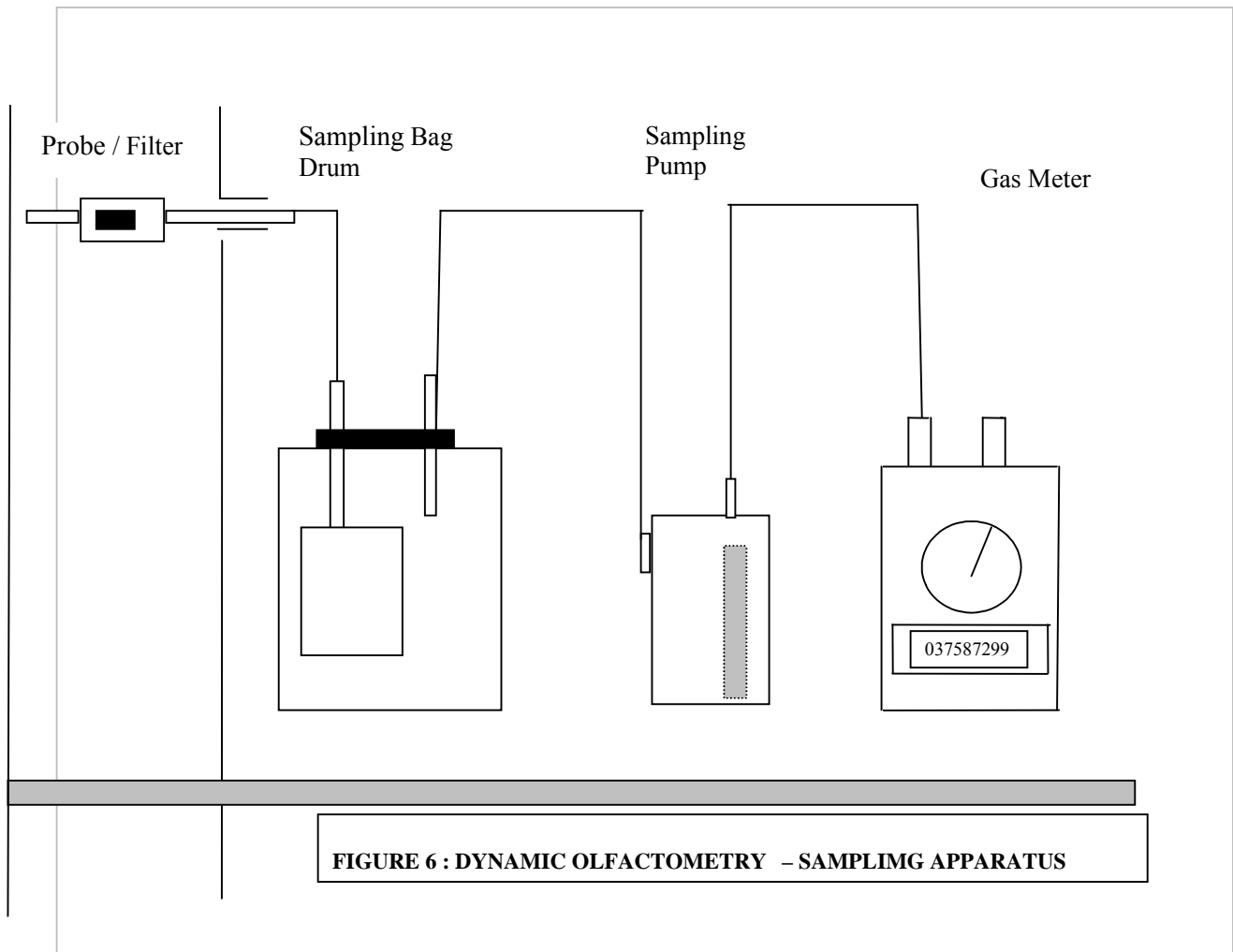

The solutions are placed into wide mouth jars. Each group contains two jars containing vanillin and two containing methyl salicylate. At the concentrations listed the odour of vanillin and methyl salicylate are similar. The degree of difficulty in distinguishing between the two odorant increases with decreasing concentration.

Three jars are selected from each group for evaluation. The candidate sniffs each set of three test solutions, commencing with the highest solution concentration (set 1), and attempts to select the odd odorant. The candidate's results are reported on a data sheet containing date, name, contact details and response (A, B or C) for each test solution set.

Candidates are subsequently classified according to the following criteria:

Group	Candidate classification	No. of correct observations
1	Excellent	6
2	Good	5
3	Satisfactory	4
4	Unsatisfactory	≤3

Candidates from groups 1, 2 and 3 are suitable odour panelists. It is essential that when the test solutions are not in use they are stored in sealed brown glass containers in the dark. Fresh solutions must be made after a period of two weeks.

The order in which the solution containing the odd odorant is provided to the candidates should also be randomly varied.

Odour panellists must be retested using the above screening process every twelve months.

### Odour Testing

The testing booths and associated dilution equipment must be located in a room isolated from other odour sources, equipped with a ventilation system capable of preventing any increase in the concentration of odorant under investigation. For odour testing the Panellists:

- Must be free of colds or physical conditions that may affect the sense of smell;
- Must not chew gum or eat at least 30 minutes prior to the odour panel;
- Must refrain from eating spicy foods prior to the odour panel;
- Must not wear perfume, cologne, or after shave the day of the odour panel;
- Must wear unscented deodorant the day of the odour panel;
- Must avoid other fragrance cosmetics, soaps, etc. the day of the odour panel;
- Must have their hands clean and free of odour the day of the odour panel;
- Must have their cloths odour free the day of the odour panel;
- Must keep the odour panel work confidential
- Must not suffer from respiratory complaints (colds, influenza or hypersensitivity to the chemical compound under investigation).
- Must not eat, drink or smoke during the 1 hr preceding the test period.

The use of experienced panellists is also preferred. Three panellists are seated in booths which normally contain a switch by which they can electrically signal their response to the panel operator. The booths are also divided to prevent visual distractions.

The odour dilution apparatus (Figure-3) consists of a series of four sample flow meters with nominal ranges of 0-10 ml/min; 0-100 ml/min; 0-1000 ml/min; 0-10,000 ml/min, and a diluent air flow meter set at a flow rate of 50 l/min. The diluent air supply must be odour free. The sample bag is connected to the sample flow meters and the drum placed under pressure. The flow meter used is dependent on the sample strength.

The known sample gas flow is then dynamically diluted in a mixing chamber using record if they can detect any odour. No subjective judgements are made with respect to the strength or type of odour. The sample gas flow meter setting is adjusted in order to obtain responses near the odour threshold. The sample odour should be replaced periodically with diluent air to confirm panel response. At the commencement and completion of each odour test the dilution apparatus must be flushed with diluent air until it is free from any perceptible odour. If odour is still detected in the diluent air passing through the apparatus, it must be cleaned prior to further use. Adsorbed odorous compounds can be removed by placing the PTFE tubing in an oven at 100-150°C, whilst passing odour free air or nitrogen through it. Organic solvent rinsing is also acceptable, however, it must be ensured that all traces of solvent are removed prior to re-use.

Odour levels obtained by the draft Australian Standard Dynamic Dilution Olfactometry test method typically range from 10 to 100,000 O.U., however, this is dependent on the equipment design and the amount of sample pre-dilution. Each sniffing port has a flow rate of 17 l/min.

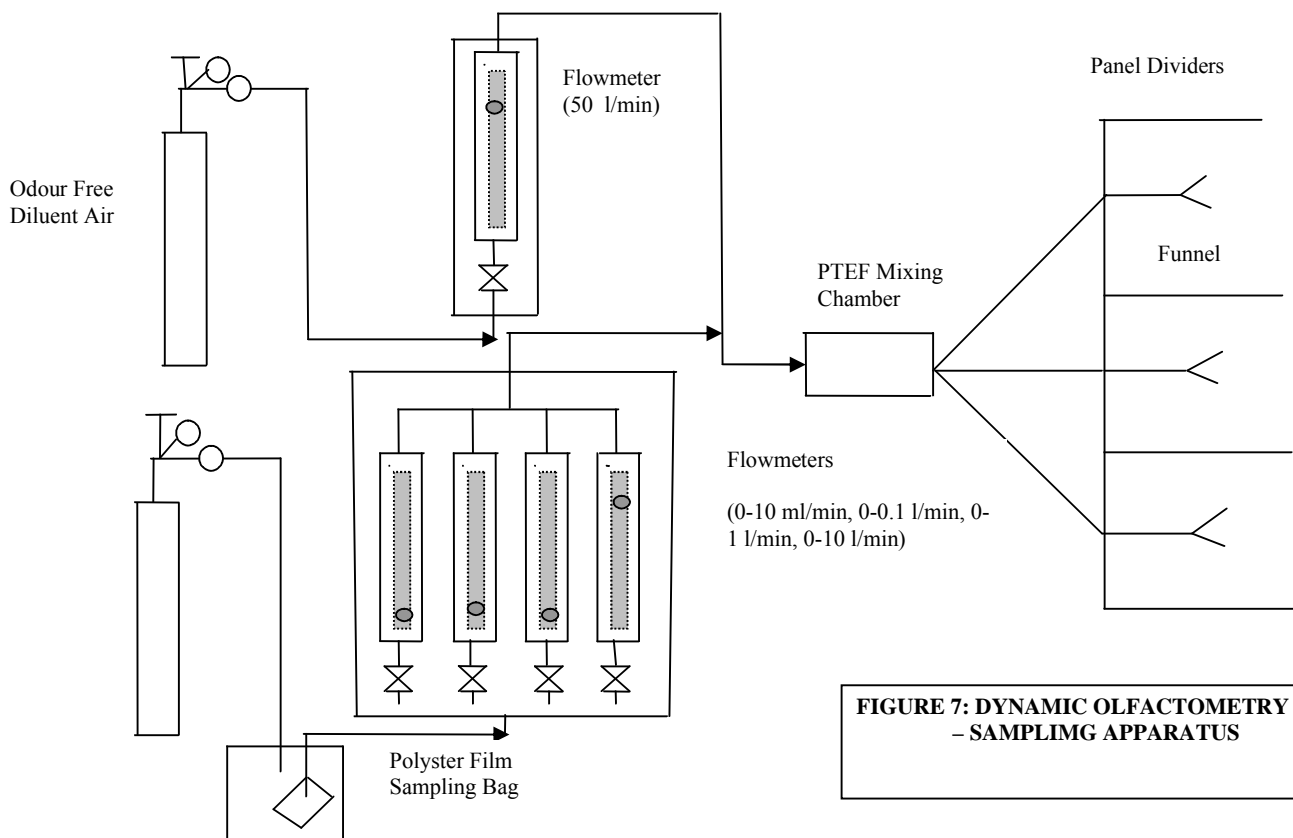

**FIGURE 7: DYNAMIC OLFACTOMETRY - SAMPLING APPARATUS**

### ***FORCED CHOICE DYNAMIC OLFACTOMETRY***

The Dutch Pre-Standard on Olfactometry published in 1990 describes a forced choice procedure for dynamic olfactometry. The basic principle of diluting the odorous sample with odour free air to determine the odour detection threshold remains the same. The olfactometer however, consists of a mixing chamber and two or three sniffing ports through which the diluted sample or odour free air can be discharged. The diluted sample is switched randomly between the sniffing ports. For each presentation the olfactometer operator decides which of the sniffing ports contains the diluted sample. The panellist must then attempt to select the port which contains the odour, even if no difference can be discerned between the sniffing ports. Each series of sample dilutions is presented to each panelist at least on two occasions. The period for assessing each dilution must be between 10-20 secs, with a minimum interval of 30 seconds between two measurements.

Odour levels obtained by Dutch Pre-Standard on Olfactometry test method typically range between 4-60,000 O.U. Each sniffing port has a flow rate of 20 l/min.

**ODOUR CONTROL IN TANNERY**

*(International Union of Environment (IUE) Commission of IULTCS Document on “Environmental Update on World Leather Sector” Chapter 8, Odour Control in Tannery - May 2006)*

Odours in tanneries have various origins. They mainly originate from the putrefaction of hides, skins, trimmings and fleshing, from the release of hydrogen sulphide and ammonia, and from the use of volatile organic compounds (VOCs). They can also occur in the wastewater treatment both in effluent processing and in sludge de-watering. Odours are no longer accepted by communities. This document gives some recommendations for the control of odours both inside and outside tanneries.

**Air treatment**

Tanneries should be well ventilated and the air from odorous areas should be exhausted and treated. Air treatment can be done biologically by blowing the odorous air through a moist bio-filter bed (compost, peat, humus) rich in micro-organisms. For effective elimination of the odour, retention time of about 20 seconds is recommended. These biofilters are now widely used and are very cost effective. Air can also be scrubbed using chemical treatments (acid, alkali and oxidant washing of the air), but running costs are higher. Areas requiring treatment include delimiting drums and areas where VOCs such as glutaraldehyde and solvents are used.

**Putrefaction**

Care should be taken in the preservation and storage of wet salted hides/skins, particularly in hot weather. Cooling equipment can be used to maintain storage temperatures below 30°C.

Putrefaction of untanned solid waste can be an important source of odour. Wet waste should only be kept in the factory for a very limited time and can be partially stabilised with lime or by cooling.

**Hydrogen sulphide**

The very toxic gas hydrogen sulphide (H<sub>2</sub>S) has the odour of rotten eggs and is released when sulphide-containing liquors or hides are acidified. This occurs in delimiting and when alkaline effluent liquors mix with acidic streams. Concentrations of 200 ppm H<sub>2</sub>S for 1 min can cause loss of consciousness, 500 ppm causes a deep coma with convulsions and exposure for 1 min at 900 ppm causes death. The limits for exposure are 10 ppm for 8 hours or 15 ppm for 15 min. The odour threshold for H<sub>2</sub>S is 0.08-2 ppm. H<sub>2</sub>S is especially dangerous because at levels over 200 ppm the odour is no longer detectable by the human nose. Portable detection devices are therefore essential.

Deliming should be done in a closed vessel to reduce release of both H<sub>2</sub>S and ammonia. The addition of small quantities of oxidising compounds (such as hydrogen peroxide or sodium bisulphite) can reduce H<sub>2</sub>S release during deliming.

Effluent from unhairing and liming processes contains high concentrations of sulphide. These liquors should be oxidised, usually using manganese sulphate as a catalyst, before being mixed with acid effluent or being discharged to the general mixing tank which generally has a pH of 8.5 - 9. Alkaline and acid floats should be kept separately in the tannery.

### **Wastewater treatment and sludges**

Effluent is an important source of odour. H<sub>2</sub>S release occurs at different steps and care should be taken to limit its formation by maintaining the pH over 10 in the equalising tank and in the sulphide oxidation tank. H<sub>2</sub>S is also generated when sulphate containing liquors and sludges become anaerobic. Anaerobic conditions in tannery waste are odorous and dangerous. Low levels of manganese sulphate can help to avoid odours in treated effluent as it facilitates the oxidation of any sulphides present.

Tannery sludge storage in a thickener, or at a dry solid content below 30%, causes noxious odours. Sludges can be stabilised with lime to minimize odour problems. It is recommended that sludges are in the thickener for the minimum time and are quickly de-watered by centrifugation or filter press and dried. Biofilters can also be used to treat the air in areas where sludge is thickened and de-watered.

### **Volatile organic compounds**

The VOCs in tanneries include solvents used in finishing, dry-cleaning and degreasing, cross-linking agents, polymeric finishing agents and volatile tanning agents. The finishing step is one of the main sources of VOCs, for example, butyl acetate, ethyl acetate, acetone, methyl isobutylketone and methyl ethylketone. They should be restricted to a minimum.

Most VOCs used in tanneries have a strong smell and many of them, including aqueous-based products such as formaldehyde, glutaraldehyde, etc. are toxic when present in the air at low concentrations (there is a safety limit of 0.6 mg/m<sup>3</sup> for formaldehyde). All areas where VOCs may be present should be well ventilated and the air should be exhausted and treated appropriately.

Solvent degreasing is a source of odour. Care should be taken to control odours during float recovery, solvent distillation or skins storage.

Cleaning solvents can be used in various steps of the process, mainly for maintenance purpose. Storage of leather with finishes containing organic solvents can lead to occupational safety and health problems if ventilation is not adequate.

Ref: International Union of Environment (IUE) Commission of IULTCS Document on “Environmental Update on World Leather Sector” Chapter 8, Odour Control in Tannery - May 2006

**MEASUREMENT AND CONTROL METHODS FOR SULPHUROUS  
ODORANTS**

*(Presentation by Shri Hemant Joglekar, National Chemical Laboratory, Pune on  
Measurement and Control of Sulphurous Odorants)*

**Methods for Measurement**

The methods for measurement of odorous sulphur compounds can be broadly classified into three categories: subjective, manual and instrumental.

**Subjective methods**

Dynamic dilution Olfactometry is developed as a subjective method to measure the dilution at which the odour is detected of a given sample of gas by fifty percent of the panellists. The method cannot quantify the odourous gas present and cannot be used to measure different odorous gases when they are present simultaneously. Moreover it requires a panel of trained persons and depends on their ability to smell a particular odorous compound.

**Manual methods**

Manual methods involve absorption or adsorption of odorous sulphides in alkali solutions or lead/mercury salts and gravimetric measurement of resultant precipitated sulphides or by colour of lead or mercury sulphide. The method depends on the efficiency of absorption or adsorption and it will not give accurate results at lower concentrations of odour. Large volume of sample is required to be passed to get measurable sulphides. The method cannot distinguish between different sulphur compounds. It can be used if a single known odorous compound is present and at concentrations above ppm level.

**Instrumental methods**

A number of detectors can measure total sulphur content of odorous sulphur compounds. These detectors are used after a gas chromatograph which separates different sulphur compounds according to their respective residence time, can quantify the respective odorous sulphur compounds.

**1. GC-TCD**

Thermal conductivity detector measures the change in thermal conductivity of the gas passing over an electrically heated resistance. By knowing the gas which is separated by GC and by measuring its thermal conductivity, the concentration of that gas in the sample can be calculated by the instrument.

## **2. GC-PIN**

Photo ionization detector ionizes the sulphur containing compounds by a beam of ultraviolet light and when an electric field is applied across the ionized gas cloud, a current flows between the electrodes. By measuring the magnitude of that current, sulphur compound separated by gas chromatograph is quantified. It can measure these compounds up to ppb level. It is comparatively cheap.

## **3. GC-FID**

Flame ionization detector ionizes the sulphur compounds by passing them through a flame. By measuring the magnitude of the current, corresponding sulphur compounds are quantified. It can measure odorous sulphur compounds up to ppb level. It is slightly costlier than GC-PID

## **4. GC-FPD**

Flame photometric detector measures radiation emitted by the burnt sulphur containing molecules as they return to ground energy state. Intensity of the radiation is proportional to the amount of sulphur per unit mass of the sample. By knowing the sulphur containing compound, its quantity can be determined by GC-FPD. Carbon monoxide interferes with FPD analysis. The method is very sensitive and accurate but costly.

## **5. GC- Chemiluminiscence**

Chemiluminiscence detector measures radiation emitted by sulphur compound when it is reacted with highly oxidizing species such as fluorine or ozone used in excess. This method is specifically designed to measure sulphur compounds separated by GC. It is sensitive and costly.

## **6. GC-FPD-ECD**

Electron capture device in combination with flame photometric detector can identify and measure sulphur compounds separated by GC. The instrument is sensitive and accurate but costly.

## **7. GC-MS**

Mass spectrometer can identify and measure sulphur chemicals. However it is costly.

## **8. GC-NDIR**

Non dispersive infrared absorption device scans only that portion of infrared spectrum where peak absorption is expected. Sulphur compounds with S-H and C-S covalent bonds exhibit certain absorption which is identified by the device. The device can be used to measure sulphur chemicals up to ppm level only and is costly. Analysis will be interfered by presence of water vapour.

## **9. GC-NDUV**

Non dispersive ultraviolet fluorescence device scans fluorescence spectrum obtained when molecules excited by absorption of ultraviolet radiation, subsequently lose that energy. This method cannot be directly used for odorous sulphur compounds but can be used for sulphur dioxide formed by them by catalytic oxidation. The instrument is complicated and costly.

## **10. GC-Electrochemical cell**

Electrochemical cells produce electrical current by oxidation of the compound, which is measured to estimate the concentration of that compound. Electrochemical cells have limited life and not very accurate.

## **11. GC-Gold film detectors**

When sulphur compounds are adsorbed onto the surface of a gold film. Its electrical resistance changes proportionally to the concentration of the gas. By measuring the current concentration of corresponding sulphur compound can be estimated. Device is costly and has limited accuracy.

## **12. Electronic nose**

A number of different sensors such as conducting polymers, metal oxides and metal ions are used in the form of films which adsorb specific chemicals and their conductivity changes. Knowing the response of these sensors for a particular compound, that compound and its concentration can be determined in the given sample. Electronic nose needs to be designed for specific compounds.

Surface acoustic wave (SAW) integrating detector utilizes quartz crystal which adsorbs sulphur compounds momentarily on its surface and its acoustic frequency changes. By measuring this change the compound and its concentration can be estimated, when SAW is used in combination with GC. This method also needs to be developed for specific odorants.

A comparison of different methods is depicted in Table-4.

**Table-4: Comparison of Different Methods of Measurement.**

Type of method	Instrument	Lowest detection level	Accuracy	Cost	Remarks
Subjective	Olefactometer	---	----	High	Measures only intensity of odour
Manual	Absorption in alkali	Above ppm	Low	Low	Useful for Preliminary Identification
	Absorption by lead or mercury salts	--	Low	Low	
	Detector tubes	Above ppm	Low	Low	
Instruments	GC-TCD	Below ppm	Medium	Medium	
	GC-FID	ppb	High	High	
	GC-FPD	ppb	V.High	High	Most accurate
	GC-Chemiluminescence	ppb	High	High	
	GC-FID	ppb	High	Medium	Most economical for ppb level
	GC-FPD-ECD	ppb	High	Very high	
	GC-MS	Ppb	High	Very high	
	GC-NDIR	ppm	Medium	Very high	
	GC-NDUV	ppm	Medium	Very high	
	GC-Elec.Cell	Ppb	Medium	Very High	
	GC-Gold film	ppb	Medium	Very high	
	Electronic nose	Below ppm	-	High	Need to be developed

#### Selections of Method

Selection of method depends upon the purpose for which it is to be used, location at which it is used and the skill of the person who is operating it. Following factors are considered while selecting the method.

- (i) **Lowest detection limit:-** The lowest detection limit of the instrument should be about one tenth of the value of the release limit. Thus, it can be high for stack monitoring and very low for ambient monitoring. Instrument with higher detection limit can be used at source.
- (ii) **Response time:-** Response time should be as low as possible for on line monitoring and it can be long when it is used for a study.
- (iii) **Cross Interference:-** Cross interference cannot be tolerated for stack monitoring. Cross interference by other sulphur compounds is avoided by instruments used in combination with GC.
- (iv) **Accuracy:-** High accuracy is always desired while monitoring toxic gases.
- (v) **Complexity of method:-** A simple method is always desirable when operated by a person on the shop floor. Sophisticated methods can be used by laboratory personnel.
- (vi) **Portability:-** The instrument used for dedicated on line monitoring need not be portable. However, if the same instrument is to be used at a number of places – say for ambient air monitoring, it has to be portable.
- (vii) **Cost:-** The instrument cost and its operating cost have to be the lowest for the range for which it is to be used. Cheap detector tubes can serve the purpose preliminary identification and estimate. GC-PID needs to be used for ppb level accurate monitoring.

Thus for measurement of odorous sulphur compounds at ppb level GC-PID will be the most appropriate as it can measure these compounds individually up to ppb level without interference and is portable, quick in response, fairly accurate, simple and the cheapest among other instruments for this range.

### **Control of Odour**

Following pollution abatement methods are used to bring down the level of odorous sulphur compounds in the emission.

#### **1. Absorption**

Odorous sulphur compounds can be absorbed in scrubbers, using scrubbing solution such as sodium hydroxide solution in equipments such as

- (i) Packed towers
- (ii) Spray towers
- (iii) Ventury scrubbers

Multiple towers are used in series to attain maximum removal of pollutants. Absorption is particularly appropriate when sulphur compounds are emitted in large quantities at high concentrations but not suitable to bring down their concentration to ppb level. This method is cheap and widely used in industry when sulphur compounds are emitted as side products. Sulphides can be recovered from spent scrubber solution. Otherwise it need to be treated as liquid effluent.

## 2. Adsorption

Odorous sulphur compounds can be adsorbed on activated carbon. The method can be used for lower concentrations. However regeneration of carbon bed, regenerates the pollutants also. Activated alumina impregnated with potassium permanganate can adsorb and oxidize the sulphur compounds. Equipment cost is low and operating cost is moderate.

## 3. Incineration

Removal of sulphur compounds at lower concentration can be ensured by thermal or catalytic incineration. Equipment cost and operating cost and operating cost are high . Sulphur dioxide generated incinerator needs to be scrubbed.

## 4. Biological methods

Microbial organisms can degenerate odorous sulphur compounds. Bio-scrubbers use micro-organisms in liquid media. Bio-filters have micro-organism on solid beds. The method is promising and cheap but needs to be developed industrially for removal of specific odorous sulphur compounds.

Comparison of different types of control methods is depicted in Table-2.

**Table-5: Comparison of Different Control Methods**

S.No.	Odour control Method	Suitable for inlet concentration	Equipment cost	Operating cost
1.	Absorption	% Level	Low	Low
2.	Adsorption	ppm	Medium	Medium
3.	Incineration	ppm	High	High
4.	Biological methods	ppm	Low	Low

It may be appropriate to use absorption when odorous sulphur compounds are generated in large quantity and recover sulphides as by-products. Further abatement of odour may be achieved by biological methods.